



**ALLIED MACHINE
& ENGINEERING**

WOHLHAUPTER®

Holemaking Solutions for Today's Manufacturing



Boring



Reaming

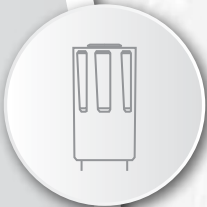

Burnishing



Threading



Specials



T-A Pro™

▶ **DRILLING**

High Penetration Replaceable Insert Drilling System

T-A Pro™

High Penetration Replaceable Insert Drilling System

► Diameter Range: 11.10mm - 47.80mm



The best just got better.

After 35 years of spade drilling success with our iconic T-A (Throw Away) insert, the best just got better. Our team of engineers developed technology that takes THE "go-to" solution for general purpose holemaking to a performance level previously unachievable by a spade insert.

The T-A Pro combines material-specific insert geometries, a redesigned drill body, and a proprietary through coolant system to allow penetration rates which run at speeds faster than other high performance drills.

Excellent chip control	Improves hole quality and surface finish	Provides maximum durability and stability
------------------------	--	---

Applicable Industries

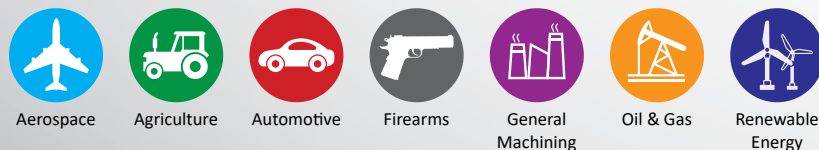

Reference Icons
The following icons will appear throughout the catalog to help you navigate between products.

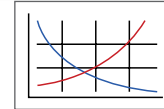

Recommended Cutting Data
Speed and feed recommendations for optimum and safe boring

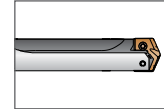

T-A Pro Holders
Refers to the range of holders that connect with the corresponding inserts

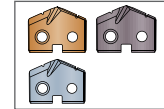

T-A Pro Carbide Inserts
Refers to ISO coated carbide inserts that connect with the corresponding holders



T-A Pro High-Speed Steel Inserts
Refers to HSS inserts that connect with the corresponding holders

Series	Diameter Range	
	Metric (mm)	Imperial (inch)
Z	11.10mm - 12.69mm	0.437" - 0.499"
0	12.70mm - 17.64mm	0.500" - 0.694"
1	17.65mm - 24.37mm	0.695" - 0.959"
2	24.38mm - 35.04mm	0.960" - 1.379"
3	35.05mm - 47.80mm	1.380" - 1.882"

Your safety and the safety of others is very important. This catalog contains important safety messages. Always read and follow all safety precautions.



This triangle is a safety hazard symbol. It alerts you to potential safety hazards that can cause tool failure and serious injury.

When you see this symbol in the catalog, look for a related safety message that may be near this triangle or referred to in the nearby text.

There are safety signal words also used in the catalog. Safety messages follow these words.

⚠ WARNING

WARNING (shown above) means that failure to follow the precautions in this message could result in tool failure and serious injury.

NOTICE means that failure to follow the precautions in this message could result in damage to the tool or machine but not result in personal injury.

NOTE and **IMPORTANT** are also used. These are important that you read and follow but are not safety-related.

Visit www.alliedmachine.com for the most up-to-date information and procedures.

T-A Pro Drilling System Contents

Introduction Information

Drill Holders	3
Competitive Test Results	4
Carbide Case Study	5
Insert Comparison and Assembly Information	6
T-A Pro Drilling System Information	7
Product Nomenclature	8 - 9

Z Series

Carbide Inserts	10
High-Speed Steel Inserts	11
Drill Holders	12

0 Series

Carbide Inserts	14 - 15
High-Speed Steel Inserts	16 - 17
Drill Holders	18 - 19

1 Series

Carbide Inserts	20 - 23
High-Speed Steel Inserts	24 - 27
Drill Holders	28 - 29

2 Series

Carbide Inserts	30 - 33
High-Speed Steel Inserts	34 - 37
Drill Holders	38 - 39

3 Series

Carbide Inserts	40 - 43
High-Speed Steel Inserts	44 - 47
Drill Holders	48 - 49

Recommended Cutting Data

Carbide	50 - 51
High-Speed Steel	52 - 53

Information and Forms

Deep Hole Drilling Guidelines	54
Tap Drill Information	55
Troubleshooting Guide	56

Guaranteed Application Form	57
-----------------------------	----

T-A Pro™

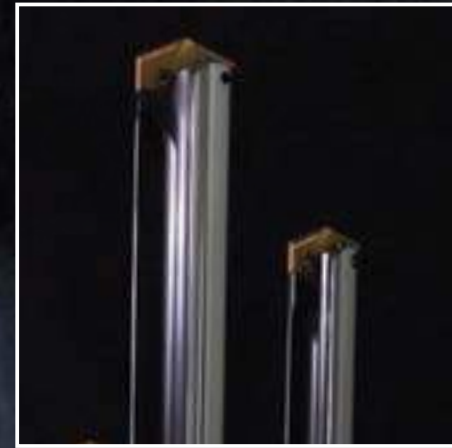

NEW HOLDER DESIGN
Optimised flute design for **increased** chip evacuation



NEW INSERT DESIGN
ISO specific geometries with a new point design to **simplify** your insert choices



NEW COOLANT DESIGN
Proprietary coolant outlet configuration provides **superior** performance even in low coolant applications (14 BAR)

Drill Holders



Stub Length



3xD



5xD



7xD



▲ 10xD



▲ 12xD



▲ 15xD

Sub Series Holders (A, B, C, D)

Sub series holders are recommended when running carbide inserts toward the upper end of the series drill range, as well as in tougher applications requiring more insert support and holder strength. NOTE: Only specified sub series inserts should be used with equivalent or smaller sub series holders.

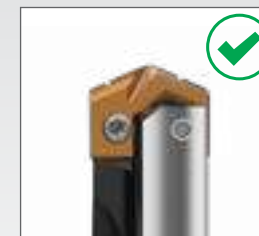

A Series Insert +
A Series Holder



C Series Insert +
A Series Holder

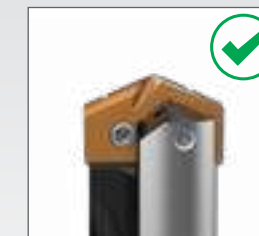

C Series Insert +
C Series Holder



A Series Insert +
C Series Holder

WARNING Refer to Speed and Feed charts for recommended adjustments to speeds and feeds. Refer to page A25: 54 for deep hole drilling guidelines in this section of the catalog. Visit www.alliedmachine.com/DeepHoleGuidelines for the most up-to-date information and procedures. Factory technical assistance is available for your specific applications through our Application Engineering department. Email: engineering.eu@alliedmachine.com

Competitive Test Results

T-A Pro™ TEST RESULTS



Project Profile: Competitive Testing in 4340 Steel
Tooling Solution: T-A Pro™: Steel (P) Geometry with T-A Pro™ Holder

- The Parameters:**
- Hole Diameter = 14.30mm
 - Depth of Cut = 50.80mm
 - Coolant = 300 PSI
 - Speed = 2546 RPM
 - Feed = 420 mm/min

The Results:
 When run at the listed parameters, here is how the 3 different tooling solutions performed:

- Competitor G** = 79.95 total linear meters
- Competitor I** = 93.67 total linear meters
- T-A Pro** = 109.62 total linear meters

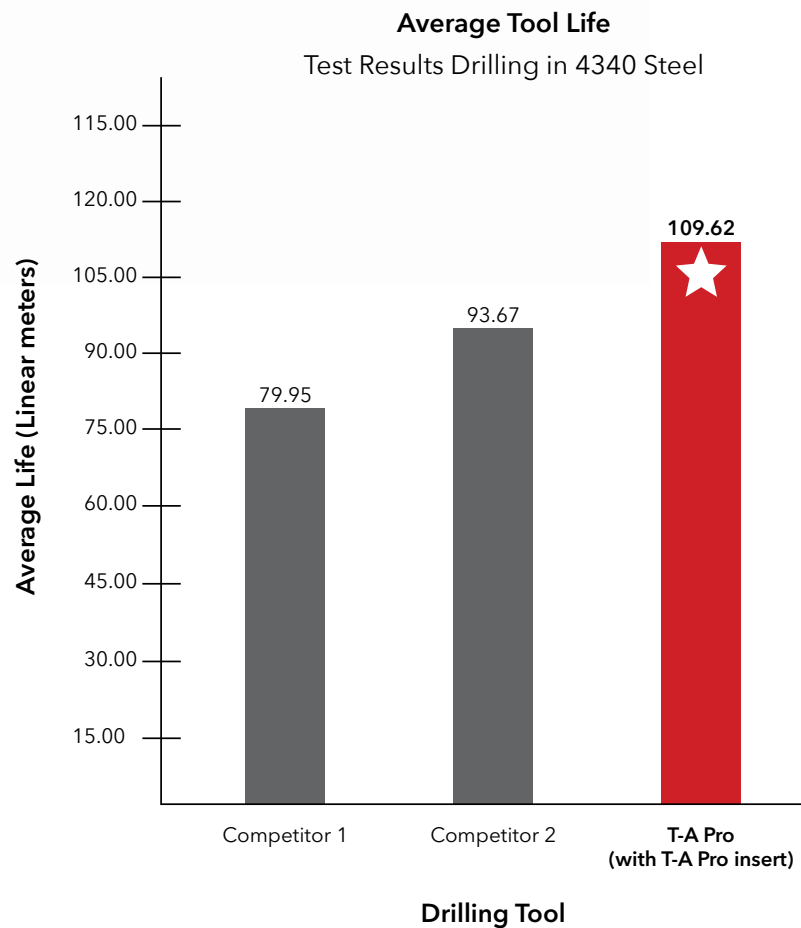

Case Study

Need a solution with better tool life?

Our customer was machining engine block parts from ductile cast iron in a production cell. The replaceable tip drill they were using wasn't providing the results they needed, so they began searching for a tooling solution that would decrease machine down time and increase productivity.

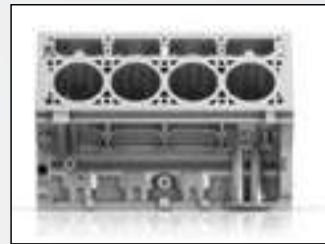

The customer tested the **T-A Pro™ High Penetration Replaceable Insert Drill** using the "K" (cast iron) geometry insert with Allied's multi-layer TiAlN coating that provides increased abrasion resistance and tool life. The T-A Pro performed better than the customer had hoped.

Using the T-A Pro not only provided substantial tool life improvements, but it also improved the penetration rate. The previous tooling had a tool life of 1700 holes, but the T-A Pro increased that life to 3400 holes. The T-A Pro also increased penetration rates by 30%. This allowed the customer to increase their productivity.

The bottom line: our customer was able to save €50k in tool savings per year with massive improvements in throughput.

The advantage of the T-A Pro allowed our customer to achieve their tooling goals.

Product:	T-A Pro™	Competitor Replaceable Insert Drill	T-A Pro™ Drill
Objectives:	(1) Decrease machine downtime (2) Increase productivity		
Industry:	Automotive		
Part:	Engine block		
Material:	Ductile Cast Iron		
Hole Ø:	16.00mm		
Hole Depth:	241.00mm		
		Measure	
		RPM	1819 RPM vs 2092 RPM
		Speed	91 M/min vs 105 M/min
		Feed Rate	0.20 mm/rev vs 0.23 mm/rev
		Penetration Rate	36.96 mm/min vs 48.89 mm/min
		Cycle Time	39 seconds vs 29 seconds
		Tool Life	1700 holes vs 3400 holes







▶ T-A Pro Drill holder
 15xD length
 Item No. **HTA0C15-20C**
 ▶ T-A Pro Drill inserts
 K geometry
 (cast iron)
 Item No. **TAK0-16.00**

increased tool life by 100%

The cast iron TiAlN T-A Pro insert coating provided:

- ✓ Doubled tool life
- ✓ Decreased machine down time
- ✓ Increased productivity
- ✓ 30% increased penetration rate
- ✓ Increased tool savings per year

Insert Comparison and Assembly Information

				
Recommended for increased productivity		<input checked="" type="checkbox"/>		
ISO specific geometry/coating combination		<input checked="" type="checkbox"/>		
Connects with T-A Pro holders		<input checked="" type="checkbox"/>	<input checked="" type="checkbox"/>	<input checked="" type="checkbox"/>
Connects with T-A holders		<input checked="" type="checkbox"/>	<input checked="" type="checkbox"/>	<input checked="" type="checkbox"/>



Step 1: Align the flats on the T-A Pro insert with the flats on the ears of the holder.

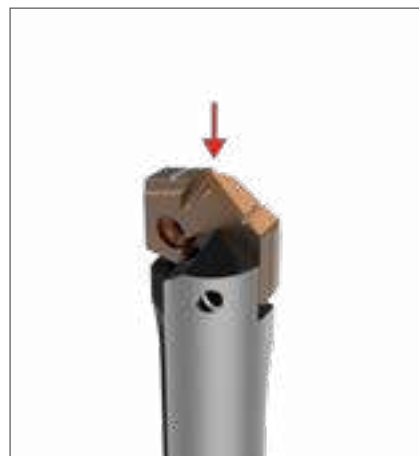

Step 2: Slide the insert into the precision ground locating pocket on the holder. The insert should not be turned, rotated, or twisted for locking purposes. The holder pocket and locating pads on the insert assure optimum fit and repeatability.



Step 3: Apply a generous amount of E-Z Break® (provided in the packaging) onto the supplied TORX® Plus screws.

Tighten the TORX Plus screws to the recommended torque value specified in the catalog by series. A preset torx driver is available to assure that the proper torque is applied.

T-A Pro Drilling System Information



Advanced Design Capabilities

The advanced T-A Pro insert combines a coating and geometry specifically designed to achieve optimal results in ISO material drilling applications. With quick connectivity to existing T-A drill insert holders, the T-A Pro insert can be interchanged with previous T-A inserts with ease, resulting in minimal setup times so you can immediately increase your productivity.

T-A Pro Inserts connect with:



P - Steels

- Designed to provide increased penetration rates and tool life in steel applications
- Superior geometry and edge provides excellent chip control
- Allied's multilayer AM300® coating increases heat resistance and improves tool life

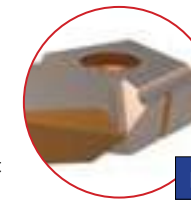

N - Non-ferrous Materials

- Designed for applications in aluminum, brass, and copper
- The geometry yields excellent chip control in these softer materials
- TiCN coating gives the versatility to run in a variety of materials while reducing buildup



K - Cast Irons

- Uniquely designed for cast/nodular iron applications
- Geometry developed for maximum tool life, reduced exit burr, and improved hole finish
- Allied's multilayer TiAlN coating provides increased abrasion resistance and tool life



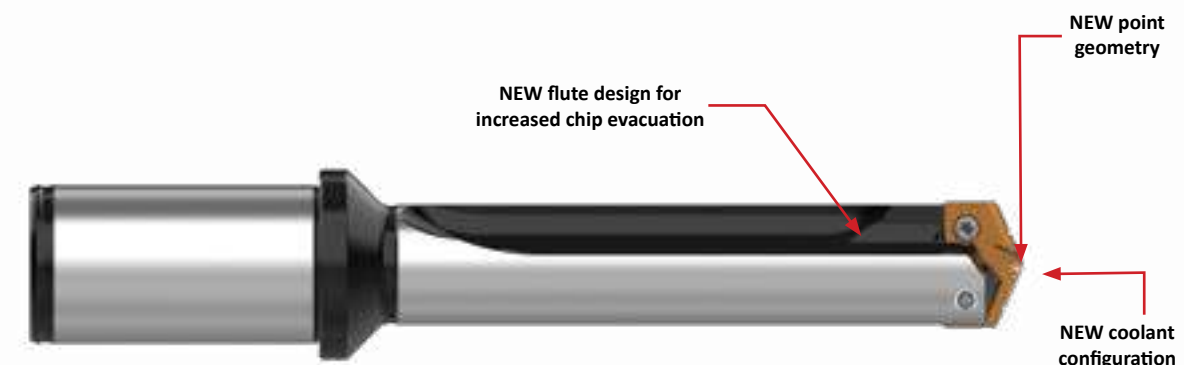

X - High-Speed Steel Materials

- Improved chip geometry for excellent chip control in all materials
- Long tool life and high-process security for the most challenging applications
- Allied's multi-layer AM200® coating combines excellent heat resistance and high lubricity for wide application use

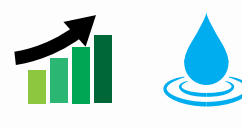

T-A Pro Drill Holders

			STUB, 3xD, 5xD, 7xD, 10xD, 12xD, 15xD
Straight flutes	Proprietary coolant outlets improve coolant flow	Provides increased insert life	Available in STUB, 3xD, 5xD, 7xD, 10xD, 12xD, and 15xD

Product Nomenclature

T-A Pro Drill Inserts

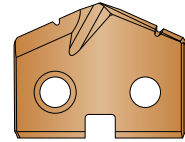

TA	P	0	-	15.00
1	2	3		4

1. T-A Pro Drill Insert	2. ISO Material / Geometry	3. Series	4. Diameter (mm)
TA = TA Pro insert	<p>P = Steel</p> <p>K = Cast iron</p> <p>N = Non-ferrous</p> <p>M = Stainless Steel</p> <p>X = HSS</p>	<p>Z = Z series</p> <p>0 = 0 series</p> <p>1 = 1 series</p> <p>2 = 2 series</p> <p>3 = 3 series</p>	For complete list of diameter ranges by series, see contents page.

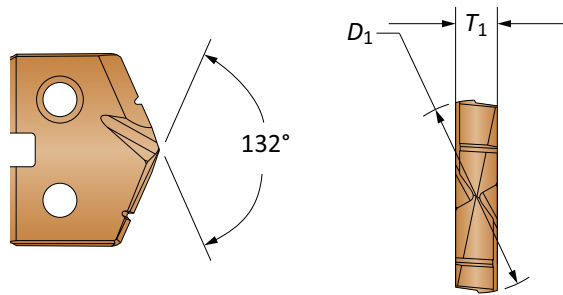

Reference Key	
Symbol	Attribute
D_1	Insert diameter
T_1	Insert thickness

Product Nomenclature

T-A Pro Drill Holders

HTA	1	A	05	-	100	C
1	2	3	4		5	6

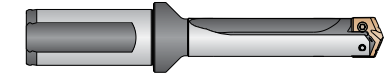

1. Holder	2. Series	3. Body Diameter	4. Length										
HTA = TA Pro holder	<p>Z = Z Series</p> <p>0 = 0 Series</p> <p>1 = 1 Series</p> <p>2 = 2 Series</p> <p>3 = 3 Series</p>	<p>A = A body diameter</p> <p>B = B body diameter</p> <p>C = C body diameter</p> <p>D = D body diameter</p>	<p>01 = Stub Length</p> <p>03 = 3x Diameter</p> <p>05 = 5x Diameter</p> <p>07 = 7x Diameter</p> <p>10 = 10x Diameter</p> <p>12 = 12x Diameter</p> <p>15 = 15x Diameter</p>										
5. Shank Diameter		6. Shank Style											
<table border="1"> <thead> <tr> <th>Metric (mm)</th> <th>Imperial (inch)</th> </tr> </thead> <tbody> <tr> <td>20 = 20mm</td> <td>075 = 3/4"</td> </tr> <tr> <td>25 = 25mm</td> <td>100 = 1"</td> </tr> <tr> <td>32 = 32mm</td> <td>125 = 1-1/4"</td> </tr> <tr> <td>40 = 40mm</td> <td>150 = 1-1/2"</td> </tr> </tbody> </table>	Metric (mm)	Imperial (inch)	20 = 20mm	075 = 3/4"	25 = 25mm	100 = 1"	32 = 32mm	125 = 1-1/4"	40 = 40mm	150 = 1-1/2"	<p>F = Flanged with flat</p> <p>FM = Flanged metric with flat</p> <p>C = Cylindrical (no flat)</p> <p>CM = Cylindrical metric (no flat)</p>		
Metric (mm)	Imperial (inch)												
20 = 20mm	075 = 3/4"												
25 = 25mm	100 = 1"												
32 = 32mm	125 = 1-1/4"												
40 = 40mm	150 = 1-1/2"												

Holder Ordering Information

The series designator (Z series, 0 series, etc.) in the top corner of each page is for your reference when ordering. Please refer to these series designators when placing an order. For example, a Z series drill insert only fits into a Z series holder.

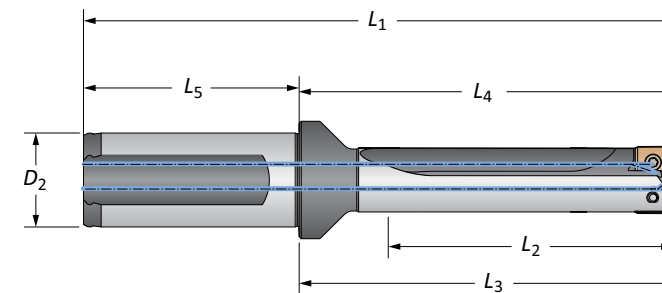

Reference Key	
Symbol	Attribute
D_2	Shank diameter
L_1	Overall length
L_2	Max. Drill depth
L_3	Holder reference length
L_4	Holder body length
L_5	Shank length

T-A Pro Carbide Drill Inserts

Z Series | Diameter Range: 11.10mm - 12.69mm

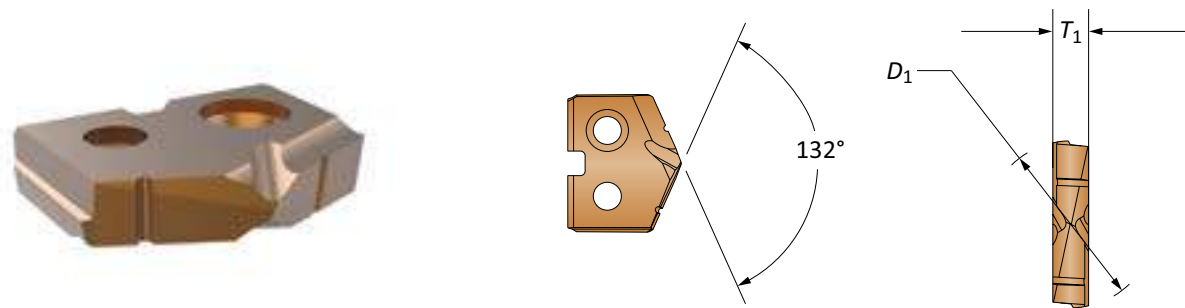

Series	Insert				Part No.		
	D ₁ mm	D ₁ inch	Fractional Equivalent	T ₁ mm	P	K	N
Z-A	11.11	0.4374	7/16	2.38	TAPZ-11.11	TAKZ-11.11	TANZ-11.11
Z-A	11.20	0.4409		2.38	TAPZ-11.20	TAKZ-11.20	TANZ-11.20
Z-A	11.30	0.4449		2.38	TAPZ-11.30	TAKZ-11.30	TANZ-11.30
Z-A	11.40	0.4488		2.38	TAPZ-11.40	TAKZ-11.40	TANZ-11.40
Z-A	11.50	0.4528		2.38	TAPZ-11.50	TAKZ-11.50	TANZ-11.50
Z-A	11.51	0.4531	29/64	2.38	TAPZ-11.51	TAKZ-11.51	TANZ-11.51
Z-A	11.60	0.4567		2.38	TAPZ-11.60	TAKZ-11.60	TANZ-11.60
Z-A	11.70	0.4606		2.38	TAPZ-11.70	TAKZ-11.70	TANZ-11.70
Z-A	11.80	0.4646		2.38	TAPZ-11.80	TAKZ-11.80	TANZ-11.80
Z-A	11.91	0.4689	15/32	2.38	TAPZ-11.91	TAKZ-11.91	TANZ-11.91
Z-A	12.00	0.4724		2.38	TAPZ-12.00	TAKZ-12.00	TANZ-12.00
Z-A	12.10	0.4764		2.38	TAPZ-12.10	TAKZ-12.10	TANZ-12.10
Z-B	12.20	0.4803		2.38	TAPZ-12.20	TAKZ-12.20	TANZ-12.20
Z-B	12.30	0.4843	31/64	2.38	TAPZ-12.30	TAKZ-12.30	TANZ-12.30
Z-B	12.40	0.4882		2.38	TAPZ-12.40	TAKZ-12.40	TANZ-12.40
Z-B	12.50	0.4921		2.38	TAPZ-12.50	TAKZ-12.50	TANZ-12.50
Z-B	12.60	0.4961		2.38	TAPZ-12.60	TAKZ-12.60	TANZ-12.60

Inserts sold in multiples of 2

T-A Pro HSS Drill Inserts

Z Series | Diameter Range: 11.10mm - 12.69mm

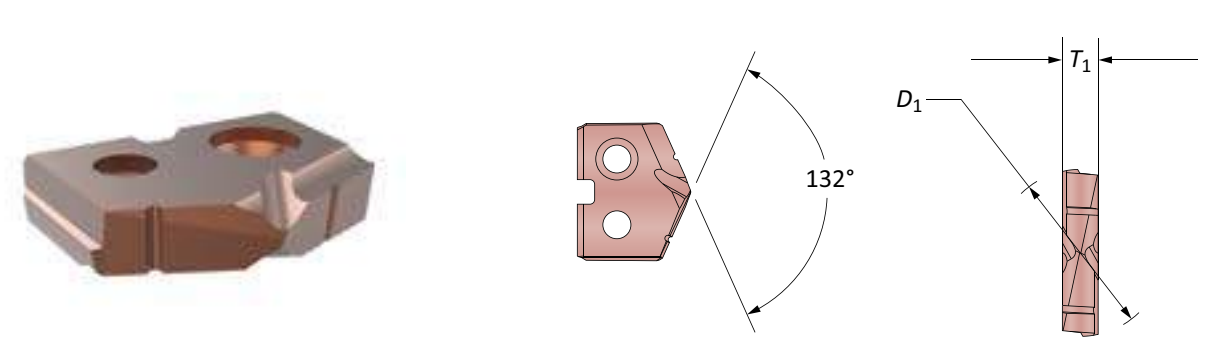

Series	Insert				Part No.
	D ₁ mm	D ₁ inch	Fractional Equivalent	T ₁ mm	X
Z-A	11.11	0.4374	7/16	2.38	TAXZ-11.11
Z-A	11.20	0.4409		2.38	TAXZ-11.20
Z-A	11.30	0.4449		2.38	TAXZ-11.30
Z-A	11.40	0.4488		2.38	TAXZ-11.40
Z-A	11.50	0.4528		2.38	TAXZ-11.50
Z-A	11.51	0.4531	29/64	2.38	TAXZ-11.51
Z-A	11.60	0.4567		2.38	TAXZ-11.60
Z-A	11.70	0.4606		2.38	TAXZ-11.70
Z-A	11.80	0.4646		2.38	TAXZ-11.80
Z-B	11.91	0.4689	15/32	2.38	TAXZ-11.91
Z-B	12.00	0.4724		2.38	TAXZ-12.00
Z-B	12.10	0.4764		2.38	TAXZ-12.10
Z-B	12.20	0.4803		2.38	TAXZ-12.20
Z-B	12.30	0.4843	31/64	2.38	TAXZ-12.30
Z-B	12.40	0.4882		2.38	TAXZ-12.40
Z-B	12.50	0.4921		2.38	TAXZ-12.50
Z-B	12.60	0.4961		2.38	TAXZ-12.60

Inserts sold in multiples of 2

Sub Series Holders (A, B, C, D)

Sub series holders are recommended when running carbide inserts toward the upper end of the series drill range, as well as in tougher applications requiring more insert support and holder strength. NOTE: Only specified sub series inserts should be used with equivalent or smaller sub series holders.

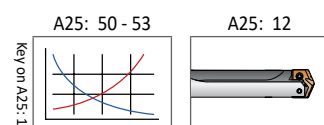
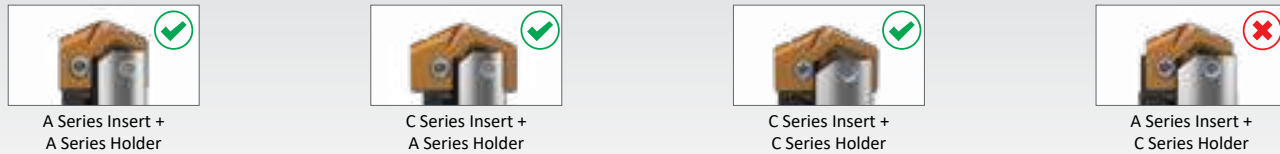

Sizes not shown are available upon request. When ordering, please follow the example below:
Metric: 13.16mm, Steel, 0 series = use Part No. **TAP0-13.16**
Imperial: 0.5180", Steel, 0 series = use Part No. **TAP0-13.16**

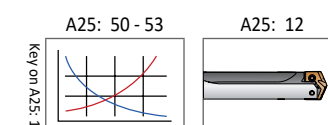

Sizes not shown are available upon request. When ordering, please follow the example below:
Metric: 13.16mm, Steel, 0 series = use Part No. **TAP0-13.16**
Imperial: 0.5180", Steel, 0 series = use Part No. **TAP0-13.16**

T-A Pro Drill Holders

Z Series Metric | Diameter Range: 11.10mm - 12.69mm

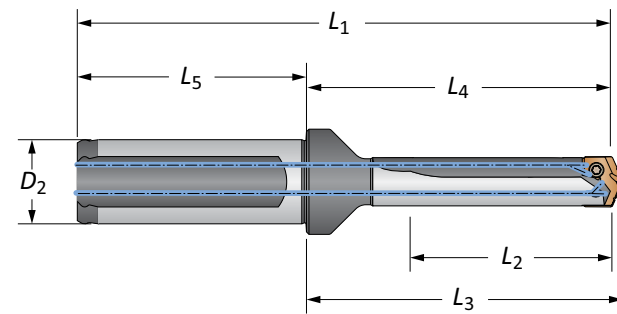

Length	Sub Series	Series Diameter	Body				Shank			Flat	Part No
			L ₂ mm	L ₄ mm	L ₃ mm	L ₁ mm	L ₅ mm	D ₂ mm			
STUB	A	11.11 - 11.80	12.8	40.7	43.4	90.7	50	20	Yes	HTAZA01-20FM	
STUB	A	11.11 - 11.80	12.8	40.7	43.4	90.7	50	20	No	HTAZA01-20CM	
STUB	B	11.91 - 12.60	12.8	40.7	43.4	90.7	50	20	Yes	HTAZB01-20FM	
STUB	B	11.91 - 12.60	12.8	40.7	43.4	90.7	50	20	No	HTAZB01-20CM	
3xD	A	11.11 - 11.80	36.9	68.4	71.2	118.4	50	20	Yes	HTAZA03-20FM	
3xD	A	11.11 - 11.80	36.9	68.4	71.2	118.4	50	20	No	HTAZA03-20CM	
3xD	B	11.91 - 12.60	36.9	68.4	71.2	118.4	50	20	Yes	HTAZB03-20FM	
3xD	B	11.91 - 12.60	36.9	68.4	71.2	118.4	50	20	No	HTAZB03-20CM	
5xD	A	11.11 - 11.80	61.0	92.5	95.3	142.5	50	20	Yes	HTAZA05-20FM	
5xD	A	11.11 - 11.80	61.0	92.5	95.3	142.5	50	20	No	HTAZA05-20CM	
5xD	B	11.91 - 12.60	61.0	92.5	95.3	142.5	50	20	Yes	HTAZB05-20FM	
5xD	B	11.91 - 12.60	61.0	92.5	95.3	142.5	50	20	No	HTAZB05-20CM	
7xD	A	11.11 - 11.80	85.0	116.5	119.3	166.6	50	20	Yes	HTAZA07-20FM	
7xD	A	11.11 - 11.80	85.0	116.5	119.3	166.6	50	20	No	HTAZA07-20CM	
7xD	B	11.91 - 12.60	85.0	116.5	119.3	166.6	50	20	Yes	HTAZB07-20FM	
7xD	B	11.91 - 12.60	85.0	116.5	119.3	166.6	50	20	No	HTAZB07-20CM	
10xD	A	11.11 - 11.80	121.2	152.7	155.5	202.7	50	20	Yes	HTAZA10-20FM	
10xD	A	11.11 - 11.80	121.2	152.7	155.5	202.7	50	20	No	HTAZA10-20CM	
10xD	B	11.91 - 12.60	121.2	152.7	155.5	202.7	50	20	Yes	HTAZB10-20FM	
10xD	B	11.91 - 12.60	121.2	152.7	155.5	202.7	50	20	No	HTAZB10-20CM	
12xD	A	11.11 - 11.80	145.2	176.7	179.5	226.8	50	20	Yes	HTAZA12-20FM	
12xD	A	11.11 - 11.80	145.2	176.7	179.5	226.8	50	20	No	HTAZA12-20CM	
12xD	B	11.91 - 12.60	145.2	176.7	179.5	226.8	50	20	Yes	HTAZB12-20FM	
12xD	B	11.91 - 12.60	145.2	176.7	179.5	226.8	50	20	No	HTAZB12-20CM	
15xD	A	11.11 - 11.80	181.4	212.9	215.7	262.9	50	20	Yes	HTAZA15-20FM	
15xD	A	11.11 - 11.80	181.4	212.9	215.7	262.9	50	20	No	HTAZA15-20CM	
15xD	B	11.91 - 12.60	181.4	212.9	215.7	262.9	50	20	Yes	HTAZB15-20FM	
15xD	B	11.91 - 12.60	181.4	212.9	215.7	262.9	50	20	No	HTAZB15-20CM	

This Page was intentionally left blank.

Connection Accessories

Insert Screws	Nylon Locking Screws	Insert Driver	Preset Torque Hand Driver	Replacement Tips	Admissible Tightening Torque*
7247-IP7-1	7247N-IP7-1	8IP-7	8IP-7TL	8IP-7B	84 N-cm

*Tightening torques are calculated with a friction coefficient of $\mu = 0.14$ and develop 90% of ultimate yield strength

WARNING Refer to Speed and Feed charts for recommended adjustments to speeds and feeds. Refer to page A25: 54 for deep hole drilling guidelines in this section of the catalog. Visit www.alliedmachine.com/DeepHoleGuidelines for the most up-to-date information and procedures. Factory technical assistance is available for your specific applications through our Application Engineering department. Email: engineering.eu@alliedmachine.com



Ⓜ = Metric (mm)
 ⓘ = Imperial (in)
 Screws sold in multiples of 10

T-A Pro Carbide Drill Inserts

0 Series | Diameter Range: 12.70mm - 17.64mm

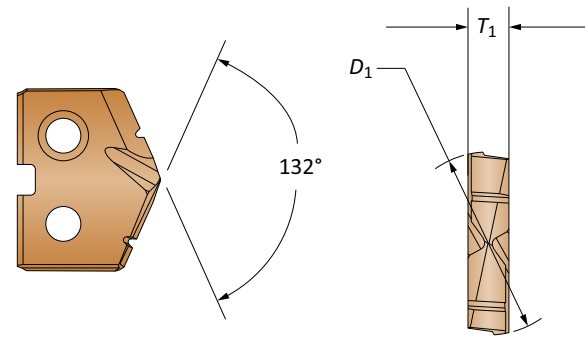

Series	Insert				Part No. P	Part No. K	Part No. N
	D ₁ mm	D ₁ inch	Fractional Equivalent	T ₁ mm			
0-A	12.70	0.5000	1/2	3.175	TAP0-12.70	TAKO-12.70	TANO-12.70
0-A	12.80	0.5039		3.175	TAP0-12.80	TAKO-12.80	TANO-12.80
0-A	12.90	0.5079		3.175	TAP0-12.90	TAKO-12.90	TANO-12.90
0-A	13.00	0.5118		3.175	TAP0-13.00	TAKO-13.00	TANO-13.00
0-A	13.10	0.5157	33/64	3.175	TAP0-13.10	TAKO-13.10	TANO-13.10
0-A	13.20	0.5197		3.175	TAP0-13.20	TAKO-13.20	TANO-13.20
0-A	13.30	0.5236		3.175	TAP0-13.30	TAKO-13.30	TANO-13.30
0-A	13.40	0.5276		3.175	TAP0-13.40	TAKO-13.40	TANO-13.40
0-A	13.49	0.5311	17/32	3.175	TAP0-13.49	TAKO-13.49	TANO-13.49
0-A	13.50	0.5315		3.175	TAP0-13.50	TAKO-13.50	TANO-13.50
0-A	13.60	0.5354		3.175	TAP0-13.60	TAKO-13.60	TANO-13.60
0-A	13.70	0.5394		3.175	TAP0-13.70	TAKO-13.70	TANO-13.70
0-A	13.80	0.5433		3.175	TAP0-13.80	TAKO-13.80	TANO-13.80
0-A	13.89	0.5469	35/64	3.175	TAP0-13.89	TAKO-13.89	TANO-13.89
0-B	14.00	0.5512		3.175	TAP0-14.00	TAKO-14.00	TANO-14.00
0-B	14.10	0.5551		3.175	TAP0-14.10	TAKO-14.10	TANO-14.10
0-B	14.20	0.5591		3.175	TAP0-14.20	TAKO-14.20	TANO-14.20
0-B	14.29	0.5626	9/16	3.175	TAP0-14.29	TAKO-14.29	TANO-14.29
0-B	14.40	0.5669		3.175	TAP0-14.40	TAKO-14.40	TANO-14.40
0-B	14.50	0.5709		3.175	TAP0-14.50	TAKO-14.50	TANO-14.50
0-B	14.60	0.5748		3.175	TAP0-14.60	TAKO-14.60	TANO-14.60
0-B	14.68	0.5780	13/64	3.175	TAP0-14.68	TAKO-14.68	TANO-14.68
0-B	14.80	0.5827		3.175	TAP0-14.80	TAKO-14.80	TANO-14.80
0-B	14.90	0.5866		3.175	TAP0-14.90	TAKO-14.90	TANO-14.90
0-B	15.00	0.5906		3.175	TAP0-15.00	TAKO-15.00	TANO-15.00

Inserts sold in multiples of 2

Sub Series Holders (A, B, C, D)
 Sub series holders are recommended when running carbide inserts toward the upper end of the series drill range, as well as in tougher applications requiring more insert support and holder strength. NOTE: Only specified sub series inserts should be used with equivalent or smaller sub series holders.

A Series Insert + A Series Holder

C Series Insert + A Series Holder

C Series Insert + C Series Holder

A Series Insert + C Series Holder

A25: 50 - 53

A25: 18 - 19

Sizes not shown are available upon request. When ordering, please follow the example below:

Metric:	13.16mm, Steel, 0 series = use Part No. TAP0-13.16
Imperial:	0.5180", Steel, 0 series = use Part No. TAP0-13.16

T-A Pro Carbide Drill Inserts

0 Series | Diameter Range: 12.70mm - 17.64mm

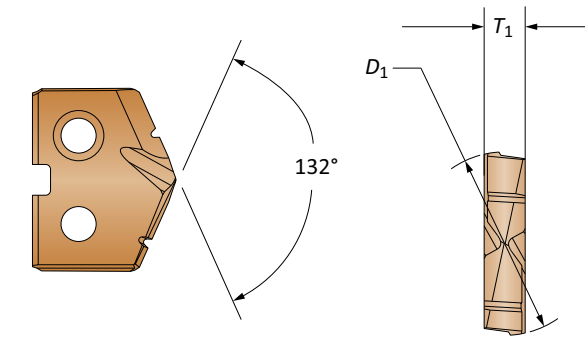

Series	Insert				Part No. P	Part No. K	Part No. N
	D ₁ mm	D ₁ inch	Fractional Equivalent	T ₁ mm			
0-C	15.08	0.5937	19/32	3.175	TAP0-15.08	TAKO-15.08	TANO-15.08
0-C	15.20	0.5984		3.175	TAP0-15.20	TAKO-15.20	TANO-15.20
0-C	15.25	0.6004		3.175	TAP0-15.25	TAKO-15.25	TANO-15.25
0-C	15.30	0.6024		3.175	TAP0-15.30	TAKO-15.30	TANO-15.30
0-C	15.40	0.6063		3.175	TAP0-15.40	TAKO-15.40	TANO-15.40
0-C	15.48	0.6094	33/64	3.175	TAP0-15.48	TAKO-15.48	TANO-15.48
0-C	15.50	0.6102		3.175	TAP0-15.50	TAKO-15.50	TANO-15.50
0-C	15.60	0.6142		3.175	TAP0-15.60	TAKO-15.60	TANO-15.60
0-C	15.70	0.6181		3.175	TAP0-15.70	TAKO-15.70	TANO-15.70
0-C	15.80	0.6220		3.175	TAP0-15.80	TAKO-15.80	TANO-15.80
0-C	15.88	0.6252	5/8	3.175	TAP0-15.88	TAKO-15.88	TANO-15.88
0-C	16.00	0.6299		3.175	TAP0-16.00	TAKO-16.00	TANO-16.00
0-C	16.08	0.6331		3.175	TAP0-16.08	TAKO-16.08	TANO-16.08
0-C	16.20	0.6378		3.175	TAP0-16.20	TAKO-16.20	TANO-16.20
0-C	16.27	0.6406	41/64	3.175	TAP0-16.27	TAKO-16.27	TANO-16.27
0-C	16.40	0.6457		3.175	TAP0-16.40	TAKO-16.40	TANO-16.40
0-D	16.50	0.6496		3.175	TAP0-16.50	TAKO-16.50	TANO-16.50
0-D	16.60	0.6535		3.175	TAP0-16.60	TAKO-16.60	TANO-16.60
0-D	16.67	0.6563	21/32	3.175	TAP0-16.67	TAKO-16.67	TANO-16.67
0-D	16.80	0.6614		3.175	TAP0-16.80	TAKO-16.80	TANO-16.80
0-D	16.90	0.6654		3.175	TAP0-16.90	TAKO-16.90	TANO-16.90
0-D	17.00	0.6693		3.175	TAP0-17.00	TAKO-17.00	TANO-17.00
0-D	17.07	0.6720	43/64	3.175	TAP0-17.07	TAKO-17.07	TANO-17.07
0-D	17.10	0.6732		3.175	TAP0-17.10	TAKO-17.10	TANO-17.10
0-D	17.20	0.6772		3.175	TAP0-17.20	TAKO-17.20	TANO-17.20
0-D	17.30	0.6811		3.175	TAP0-17.30	TAKO-17.30	TANO-17.30
0-D	17.40	0.6850		3.175	TAP0-17.40	TAKO-17.40	TANO-17.40
0-D	17.46	0.6874	11/16	3.175	TAP0-17.46	TAKO-17.46	TANO-17.46
0-D	17.50	0.6890		3.175	TAP0-17.50	TAKO-17.50	TANO-17.50
0-D	17.60	0.6929		3.175	TAP0-17.60	TAKO-17.60	TANO-17.60

Sub Series Holders (A, B, C, D)
 Sub series holders are recommended when running carbide inserts toward the upper end of the series drill range, as well as in tougher applications requiring more insert support and holder strength. NOTE: Only specified sub series inserts should be used with equivalent or smaller sub series holders.

A Series Insert + A Series Holder

C Series Insert + A Series Holder

C Series Insert + C Series Holder

A Series Insert + C Series Holder

A25: 50 - 53

A25: 18 - 19

Sizes not shown are available upon request. When ordering, please follow the example below:

Metric:	13.16mm, Steel, 0 series = use Part No. TAP0-13.16
Imperial:	0.5180", Steel, 0 series = use Part No. TAP0-13.16

T-A Pro HSS Drill Inserts

0 Series | Diameter Range: 12.70mm - 17.64mm

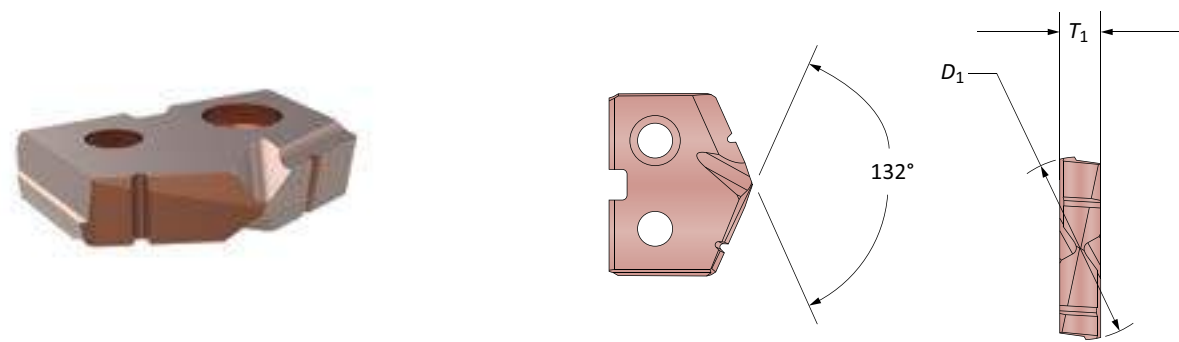

Series	Insert				Part No. X
	D ₁ mm	D ₁ inch	Fractional Equivalent	T ₁ mm	
0-A	12.70	0.5000	1/2	3.175	TAX0-12.70
0-A	12.80	0.5039		3.175	TAX0-12.80
0-A	12.90	0.5079		3.175	TAX0-12.90
0-A	13.00	0.5118		3.175	TAX0-13.00
0-A	13.10	0.5157	33/64	3.175	TAX0-13.10
0-A	13.20	0.5197		3.175	TAX0-13.20
0-A	13.30	0.5236		3.175	TAX0-13.30
0-A	13.40	0.5276		3.175	TAX0-13.40
0-A	13.49	0.5311	17/32	3.175	TAX0-13.49
0-A	13.50	0.5315		3.175	TAX0-13.50
0-A	13.60	0.5354		3.175	TAX0-13.60
0-A	13.70	0.5394		3.175	TAX0-13.70
0-A	13.80	0.5433		3.175	TAX0-13.80
0-A	13.89	0.5469	35/64	3.175	TAX0-13.89
0-B	14.00	0.5512		3.175	TAX0-14.00
0-B	14.10	0.5551		3.175	TAX0-14.10
0-B	14.20	0.5591		3.175	TAX0-14.20
0-B	14.29	0.5626	9/16	3.175	TAX0-14.29
0-B	14.40	0.5669		3.175	TAX0-14.40
0-B	14.50	0.5709		3.175	TAX0-14.50
0-B	14.60	0.5748		3.175	TAX0-14.60
0-B	14.68	0.5780	13/64	3.175	TAX0-14.68
0-B	14.80	0.5827		3.175	TAX0-14.80
0-B	14.90	0.5866		3.175	TAX0-14.90
0-B	15.00	0.5906		3.175	TAX0-15.00

Inserts sold in multiples of 2

T-A Pro HSS Drill Inserts

0 Series | Diameter Range: 12.70mm - 17.64mm

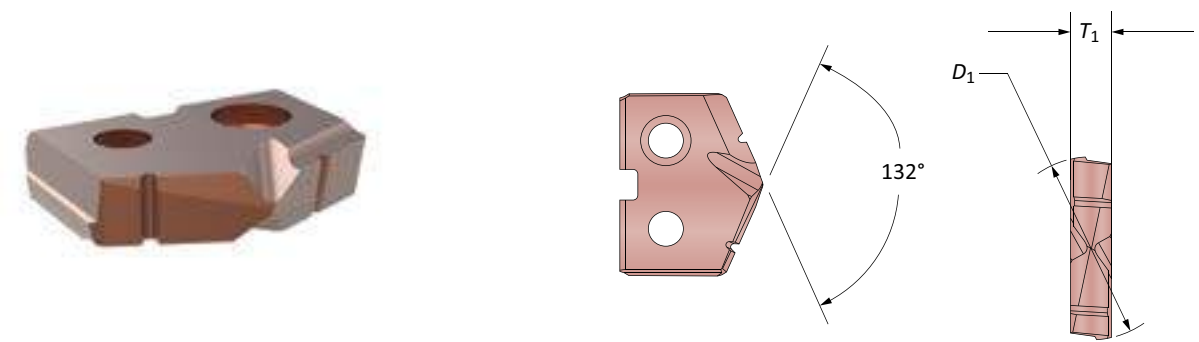

Series	Insert				Part No. X
	D ₁ mm	D ₁ inch	Fractional Equivalent	T ₁ mm	
0-C	15.08	0.5937	19/32	3.175	TAX0-15.08
0-C	15.20	0.5984		3.175	TAX0-15.20
0-C	15.25	0.6004		3.175	TAX0-15.25
0-C	15.30	0.6024		3.175	TAX0-15.30
0-C	15.40	0.6063		3.175	TAX0-15.40
0-C	15.48	0.6094	33/64	3.175	TAX0-15.48
0-C	15.50	0.6102		3.175	TAX0-15.50
0-C	15.60	0.6142		3.175	TAX0-15.60
0-C	15.70	0.6181		3.175	TAX0-15.70
0-C	15.80	0.6220		3.175	TAX0-15.80
0-C	15.88	0.6252	5/8	3.175	TAX0-15.88
0-C	16.00	0.6299		3.175	TAX0-16.00
0-C	16.08	0.6331		3.175	TAX0-16.08
0-C	16.20	0.6378		3.175	TAX0-16.20
0-C	16.27	0.6406	41/64	3.175	TAX0-16.27
0-C	16.40	0.6457		3.175	TAX0-16.40
0-D	16.50	0.6496		3.175	TAX0-16.50
0-D	16.60	0.6535		3.175	TAX0-16.60
0-D	16.67	0.6563	21/32	3.175	TAX0-16.67
0-D	16.80	0.6614		3.175	TAX0-16.80
0-D	16.90	0.6654		3.175	TAX0-16.90
0-D	17.00	0.6693		3.175	TAX0-17.00
0-D	17.07	0.6720	43/64	3.175	TAX0-17.07
0-D	17.10	0.6732		3.175	TAX0-17.10
0-D	17.20	0.6772		3.175	TAX0-17.20
0-D	17.30	0.6811		3.175	TAX0-17.30
0-D	17.40	0.6850		3.175	TAX0-17.40
0-D	17.46	0.6874	11/16	3.175	TAX0-17.46
0-D	17.50	0.6890		3.175	TAX0-17.50
0-D	17.60	0.6929		3.175	TAX0-17.60

Inserts sold in multiples of 2

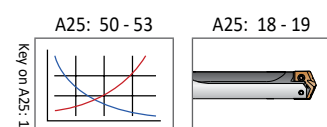

Sizes not shown are available upon request.
When ordering, please follow the example below:
Metric: 13.16mm, Steel, 0 series = use Part No. **TAP0-13.16**
Imperial: 0.5180", Steel, 0 series = use Part No. **TAP0-13.16**

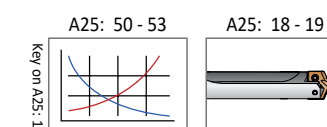

Sizes not shown are available upon request.
When ordering, please follow the example below:
Metric: 13.16mm, Steel, 0 series = use Part No. **TAP0-13.16**
Imperial: 0.5180", Steel, 0 series = use Part No. **TAP0-13.16**

T-A Pro Drill Holders

0 Series Metric | Diameter Range: 12.70mm - 17.64mm

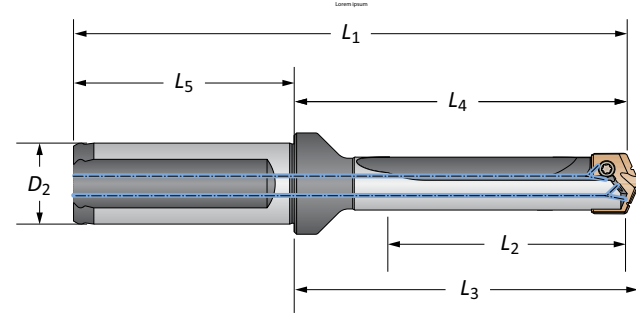

Length	Sub Series	Series Diameter	Body				Shank			Flat	Part No
			L ₂ mm	L ₄ mm	L ₃ mm	L ₁ mm	L ₅ mm	D ₂ mm			
STUB	A	12.70 - 13.89	15.3	44.0	46.7	95.5	51.6	20	Yes	HTA0A01-20FM	
STUB	A	12.70 - 13.89	15.3	44.0	46.7	95.5	51.6	20	No	HTA0A01-20CM	
STUB	B	14.00 - 15.00	15.3	44.0	46.7	95.5	51.6	20	Yes	HTA0B01-20FM	
STUB	B	14.00 - 15.00	15.3	44.0	46.7	95.5	51.6	20	No	HTA0B01-20CM	
STUB	C	15.08 - 16.40	15.3	44.0	46.7	95.5	51.6	20	Yes	HTA0C01-20FM	
STUB	C	15.08 - 16.40	15.3	44.0	46.7	95.5	51.6	20	No	HTA0C01-20CM	
STUB	D	16.50 - 17.60	15.3	44.0	46.7	95.5	51.6	20	Yes	HTA0D01-20FM	
STUB	D	16.50 - 17.60	15.3	44.0	46.7	95.5	51.6	20	No	HTA0D01-20CM	
3xD	A	12.70 - 13.89	45.9	77.8	80.5	129.4	51.6	20	Yes	HTA0A03-20FM	
3xD	A	12.70 - 13.89	45.9	77.8	80.5	129.4	51.6	20	No	HTA0A03-20CM	
3xD	B	14.00 - 15.00	45.9	77.8	80.5	129.4	51.6	20	Yes	HTA0B03-20FM	
3xD	B	14.00 - 15.00	45.9	77.8	80.5	129.4	51.6	20	No	HTA0B03-20CM	
3xD	C	15.08 - 16.40	45.9	77.8	80.5	129.4	51.6	20	Yes	HTA0C03-20FM	
3xD	C	15.08 - 16.40	45.9	77.8	80.5	129.4	51.6	20	No	HTA0C03-20CM	
3xD	D	16.50 - 17.60	45.9	77.8	80.5	129.4	51.6	20	Yes	HTA0D03-20FM	
3xD	D	16.50 - 17.60	45.9	77.8	80.5	129.4	51.6	20	No	HTA0D03-20CM	
5xD	A	12.70 - 13.89	76.6	108.5	111.2	160.0	51.6	20	Yes	HTA0A05-20FM	
5xD	A	12.70 - 13.89	76.6	108.5	111.2	160.0	51.6	20	No	HTA0A05-20CM	
5xD	B	14.00 - 15.00	76.6	108.5	111.2	160.0	51.6	20	Yes	HTA0B05-20FM	
5xD	B	14.00 - 15.00	76.6	108.5	111.2	160.0	51.6	20	No	HTA0B05-20CM	
5xD	C	15.08 - 16.40	76.6	108.5	111.2	160.0	51.6	20	Yes	HTA0C05-20FM	
5xD	C	15.08 - 16.40	76.6	108.5	111.2	160.0	51.6	20	No	HTA0C05-20CM	
5xD	D	16.50 - 17.60	76.6	108.5	111.2	160.0	51.6	20	Yes	HTA0D05-20FM	
5xD	D	16.50 - 17.60	76.6	108.5	111.2	160.0	51.6	20	No	HTA0D05-20CM	
7xD	A	12.70 - 13.89	107.2	139.1	141.8	190.7	51.6	20	Yes	HTA0A07-20FM	
7xD	A	12.70 - 13.89	107.2	139.1	141.8	190.7	51.6	20	No	HTA0A07-20CM	
7xD	B	14.00 - 15.00	107.2	139.1	141.8	190.7	51.6	20	Yes	HTA0B07-20FM	
7xD	B	14.00 - 15.00	107.2	139.1	141.8	190.7	51.6	20	No	HTA0B07-20CM	
7xD	C	15.08 - 16.40	107.2	139.1	141.8	190.7	51.6	20	Yes	HTA0C07-20FM	
7xD	C	15.08 - 16.40	107.2	139.1	141.8	190.7	51.6	20	No	HTA0C07-20CM	
7xD	D	16.50 - 17.60	107.2	139.1	141.8	190.7	51.6	20	Yes	HTA0D07-20FM	
7xD	D	16.50 - 17.60	107.2	139.1	141.8	190.7	51.6	20	No	HTA0D07-20CM	

Connection Accessories

	Insert Screws	Nylon Locking Screws	Insert Driver	Preset Torque Hand Driver	Replacement Tips	Admissible Tightening Torque*
A/B	72556-IP8-1	72556N-IP8-1	8IP-8	8IP-8TL	8IP-8B	175 N-cm (15.5 in-lbs)
C/D	72557-IP8-1	72557N-IP8-1	8IP-8	8IP-8TL	8IP-8B	175 N-cm (15.5 in-lbs)

*Tightening torques are calculated with a friction coefficient of $\mu = 0.14$ and develop 90% of ultimate yield strength

WARNING Refer to Speed and Feed charts for recommended adjustments to speeds and feeds. Refer to page A25: 54 for deep hole drilling guidelines in this section of the catalog. Visit www.alliedmachine.com/DeepHoleGuidelines for the most up-to-date information and procedures. Factory technical assistance is available for your specific applications through our Application Engineering department. Email: engineering.eu@alliedmachine.com



Ⓜ = Metric (mm)
 ⓘ = Imperial (in)
 Screws sold in multiples of 10

T-A Pro Drill Holders

0 Series Metric | Diameter Range: 12.70mm - 17.64mm

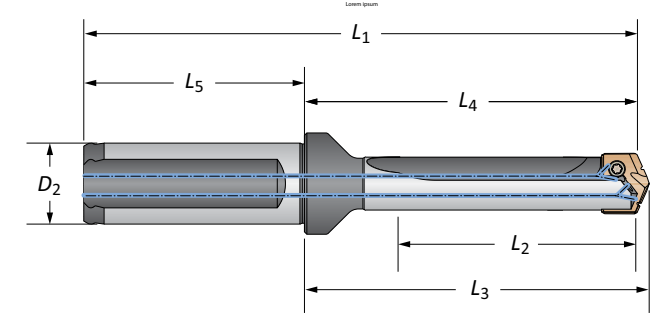

Length	Sub Series	Series Diameter	Body				Shank			Flat	Part No
			L ₂ mm	L ₄ mm	L ₃ mm	L ₁ mm	L ₅ mm	D ₂ mm			
10xD	A	12.70 - 13.89	153.2	185.0	187.8	236.6	51.6	20	Yes	HTA0A10-20FM	
10xD	A	12.70 - 13.89	153.2	185.0	187.8	236.6	51.6	20	No	HTA0A10-20CM	
10xD	B	14.00 - 15.00	153.2	185.0	187.8	236.6	51.6	20	Yes	HTA0B10-20FM	
10xD	B	14.00 - 15.00	153.2	185.0	187.8	236.6	51.6	20	No	HTA0B10-20CM	
10xD	C	15.08 - 16.40	153.2	185.0	187.8	236.6	51.6	20	Yes	HTA0C10-20FM	
10xD	C	15.08 - 16.40	153.2	185.0	187.8	236.6	51.6	20	No	HTA0C10-20CM	
10xD	D	16.50 - 17.60	153.2	185.0	187.8	236.6	51.6	20	Yes	HTA0D10-20FM	
10xD	D	16.50 - 17.60	153.2	185.0	187.8	236.6	51.6	20	No	HTA0D10-20CM	
12xD	A	12.70 - 13.89	183.8	215.7	218.4	267.2	51.6	20	Yes	HTA0A12-20FM	
12xD	A	12.70 - 13.89	183.8	215.7	218.4	267.2	51.6	20	No	HTA0A12-20CM	
12xD	B	14.00 - 15.00	183.8	215.7	218.4	267.2	51.6	20	Yes	HTA0B12-20FM	
12xD	B	14.00 - 15.00	183.8	215.7	218.4	267.2	51.6	20	No	HTA0B12-20CM	
12xD	C	15.08 - 16.40	183.8	215.7	218.4	267.2	51.6	20	Yes	HTA0C12-20FM	
12xD	C	15.08 - 16.40	183.8	215.7	218.4	267.2	51.6	20	No	HTA0C12-20CM	
12xD	D	16.50 - 17.60	183.8	215.7	218.4	267.2	51.6	20	Yes	HTA0D12-20FM	
12xD	D	16.50 - 17.60	183.8	215.7	218.4	267.2	51.6	20	No	HTA0D12-20CM	
15xD	A	12.70 - 13.89	229.7	261.6	264.3	313.2	51.6	20	Yes	HTA0A15-20FM	
15xD	A	12.70 - 13.89	229.7	261.6	264.3	313.2	51.6	20	No	HTA0A15-20CM	
15xD	B	14.00 - 15.00	229.7	261.6	264.3	313.2	51.6	20	Yes	HTA0B15-20FM	
15xD	B	14.00 - 15.00	229.7	261.6	264.3	313.2	51.6	20	No	HTA0B15-20CM	
15xD	C	15.08 - 16.40	229.7	261.6	264.3	313.2	51.6	20	Yes	HTA0C15-20FM	
15xD	C	15.08 - 16.40	229.7	261.6	264.3	313.2	51.6	20	No	HTA0C15-20CM	
15xD	D	16.50 - 17.60	229.7	261.6	264.3	313.2	51.6	20	Yes	HTA0D15-20FM	
15xD	D	16.50 - 17.60	229.7	261.6	264.3	313.2	51.6	20	No	HTA0D15-20CM	

Connection Accessories

	Insert Screws	Nylon Locking Screws	Insert Driver	Preset Torque Hand Driver	Replacement Tips	Admissible Tightening Torque*
A/B	72556-IP8-1	72556N-IP8-1	8IP-8	8IP-8TL	8IP-8B	175 N-cm (15.5 in-lbs)
C/D	72557-IP8-1	72557N-IP8-1	8IP-8	8IP-8TL	8IP-8B	175 N-cm (15.5 in-lbs)

*Tightening torques are calculated with a friction coefficient of $\mu = 0.14$ and develop 90% of ultimate yield strength

WARNING Refer to Speed and Feed charts for recommended adjustments to speeds and feeds. Refer to page A25: 54 for deep hole drilling guidelines in this section of the catalog. Visit www.alliedmachine.com/DeepHoleGuidelines for the most up-to-date information and procedures. Factory technical assistance is available for your specific applications through our Application Engineering department. Email: engineering.eu@alliedmachine.com



Ⓜ = Metric (mm)
 ⓘ = Imperial (in)
 Screws sold in multiples of 10

T-A Pro Carbide Drill Inserts

1 Series | Diameter Range: 17.65mm - 24.37mm

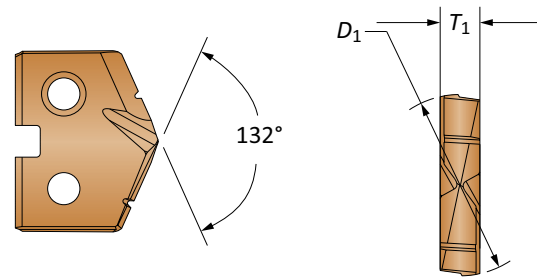

Series	Insert				Part No. P	Part No. K	Part No. N
	D ₁ mm	D ₁ inch	Fractional Equivalent	T ₁ mm			
1-A	17.70	0.6969		3.97	TAP1-17.70	TAK1-17.70	TAN1-17.70
1-A	17.80	0.7008		3.97	TAP1-17.80	TAK1-17.80	TAN1-17.80
1-A	17.86	0.7031	45/64	3.97	TAP1-17.86	TAK1-17.86	TAN1-17.86
1-A	17.90	0.7047		3.97	TAP1-17.90	TAK1-17.90	TAN1-17.90
1-A	18.00	0.7087		3.97	TAP1-18.00	TAK1-18.00	TAN1-18.00
1-A	18.10	0.7126		3.97	TAP1-18.10	TAK1-18.10	TAN1-18.10
1-A	18.20	0.7165		3.97	TAP1-18.20	TAK1-18.20	TAN1-18.20
1-A	18.26	0.7189	23/32	3.97	TAP1-18.26	TAK1-18.26	TAN1-18.26
1-A	18.30	0.7205		3.97	TAP1-18.30	TAK1-18.30	TAN1-18.30
1-A	18.40	0.7244		3.97	TAP1-18.40	TAK1-18.40	TAN1-18.40
1-A	18.50	0.7283		3.97	TAP1-18.50	TAK1-18.50	TAN1-18.50
1-A	18.60	0.7323		3.97	TAP1-18.60	TAK1-18.60	TAN1-18.60
1-A	18.65	0.7343	47/64	3.97	TAP1-18.65	TAK1-18.65	TAN1-18.65
1-A	18.70	0.7362		3.97	TAP1-18.70	TAK1-18.70	TAN1-18.70
1-A	18.80	0.7402		3.97	TAP1-18.80	TAK1-18.80	TAN1-18.80
1-A	18.90	0.7441		3.97	TAP1-18.90	TAK1-18.90	TAN1-18.90
1-A	19.00	0.7480		3.97	TAP1-19.00	TAK1-19.00	TAN1-19.00

Inserts sold in multiples of 2

Sub Series Holders (A, B, C, D)

Sub series holders are recommended when running carbide inserts toward the upper end of the series drill range, as well as in tougher applications requiring more insert support and holder strength. NOTE: Only specified sub series inserts should be used with equivalent or smaller sub series holders.

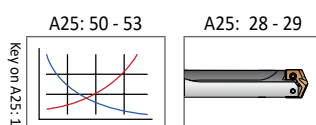
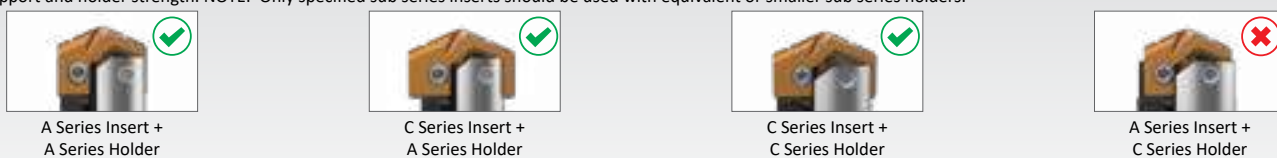

Sizes not shown are available upon request. When ordering, please follow the example below:
Metric: 13.16mm, Steel, 0 series = use Part No. **TAP0-13.16**
Imperial: 0.5180", Steel, 0 series = use Part No. **TAP0-13.16**

T-A Pro Carbide Drill Inserts

1 Series | Diameter Range: 17.65mm - 24.37mm

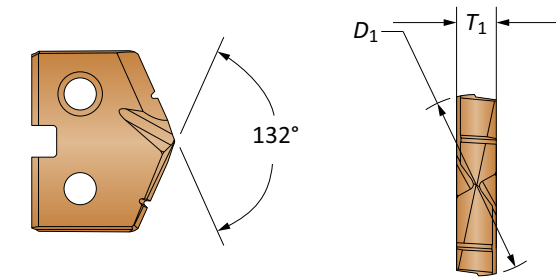

Series	Insert				Part No. P	Part No. K	Part No. N
	D ₁ mm	D ₁ inch	Fractional Equivalent	T ₁ mm			
1-B	19.05	0.7500	3/4	3.97	TAP1-19.05	TAK1-19.05	TAN1-19.05
1-B	19.10	0.7520		3.97	TAP1-19.10	TAK1-19.10	TAN1-19.10
1-B	19.20	0.7559		3.97	TAP1-19.20	TAK1-19.20	TAN1-19.20
1-B	19.25	0.7579		3.97	TAP1-19.25	TAK1-19.25	TAN1-19.25
1-B	19.30	0.7598		3.97	TAP1-19.30	TAK1-19.30	TAN1-19.30
1-B	19.40	0.7638		3.97	TAP1-19.40	TAK1-19.40	TAN1-19.40
1-B	19.45	0.7657	49/64	3.97	TAP1-19.45	TAK1-19.45	TAN1-19.45
1-B	19.50	0.7677		3.97	TAP1-19.50	TAK1-19.50	TAN1-19.50
1-B	19.60	0.7717		3.97	TAP1-19.60	TAK1-19.60	TAN1-19.60
1-B	19.70	0.7756		3.97	TAP1-19.70	TAK1-19.70	TAN1-19.70
1-B	19.80	0.7795		3.97	TAP1-19.80	TAK1-19.80	TAN1-19.80
1-B	19.84	0.7811	23/97	3.97	TAP1-19.84	TAK1-19.84	TAN1-19.84
1-B	19.90	0.7835		3.97	TAP1-19.90	TAK1-19.90	TAN1-19.90
1-B	20.00	0.7874		3.97	TAP1-20.00	TAK1-20.00	TAN1-20.00
1-B	20.10	0.7913		3.97	TAP1-20.10	TAK1-20.10	TAN1-20.10
1-B	20.20	0.7953		3.97	TAP1-20.20	TAK1-20.20	TAN1-20.20
1-B	20.24	0.7969	51/64	3.97	TAP1-20.24	TAK1-20.24	TAN1-20.24
1-B	20.30	0.7992		3.97	TAP1-20.30	TAK1-20.30	TAN1-20.30
1-B	20.40	0.8031		3.97	TAP1-20.40	TAK1-20.40	TAN1-20.40
1-B	20.50	0.8071		3.97	TAP1-20.50	TAK1-20.50	TAN1-20.50

Inserts sold in multiples of 2

Sub Series Holders (A, B, C, D)

Sub series holders are recommended when running carbide inserts toward the upper end of the series drill range, as well as in tougher applications requiring more insert support and holder strength. NOTE: Only specified sub series inserts should be used with equivalent or smaller sub series holders.

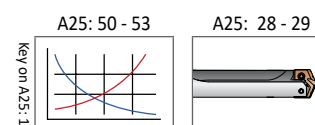
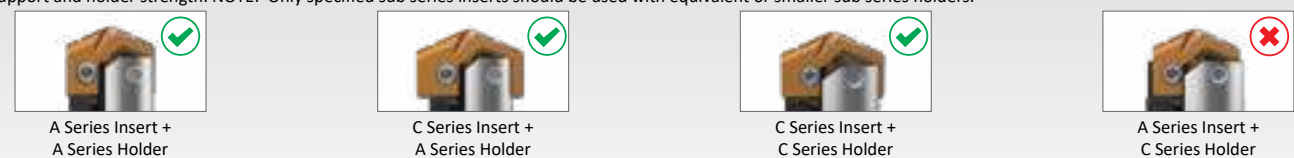

Sizes not shown are available upon request. When ordering, please follow the example below:
Metric: 13.16mm, Steel, 0 series = use Part No. **TAP0-13.16**
Imperial: 0.5180", Steel, 0 series = use Part No. **TAP0-13.16**

T-A Pro Carbide Drill Inserts

1 Series | Diameter Range: 17.65mm - 24.37mm

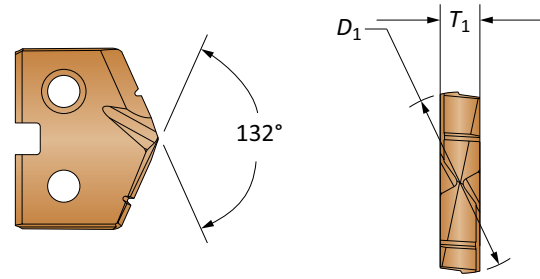

Series	Insert				Part No.		
	D ₁ mm	D ₁ inch	Fractional Equivalent	T ₁ mm	P	K	N
1-C	20.60	0.8110		3.97	TAP1-20.60	TAK1-20.60	TAN1-20.60
1-C	20.64	0.8126	13/16	3.97	TAP1-20.64	TAK1-20.64	TAN1-20.64
1-C	20.70	0.8150		3.97	TAP1-20.70	TAK1-20.70	TAN1-20.70
1-C	20.80	0.8189		3.97	TAP1-20.80	TAK1-20.80	TAN1-20.80
1-C	20.90	0.8228		3.97	TAP1-20.90	TAK1-20.90	TAN1-20.90
1-C	21.00	0.8268		3.97	TAP1-21.00	TAK1-21.00	TAN1-21.00
1-C	21.10	0.8307		3.97	TAP1-21.10	TAK1-21.10	TAN1-21.10
1-C	21.20	0.8346		3.97	TAP1-21.20	TAK1-21.20	TAN1-21.20
1-C	21.30	0.8386		3.97	TAP1-21.30	TAK1-21.30	TAN1-21.30
1-C	21.40	0.8425		3.97	TAP1-21.40	TAK1-21.40	TAN1-21.40
1-C	21.43	0.8437	27/32	3.97	TAP1-21.43	TAK1-21.43	TAN1-21.43
1-C	21.50	0.8465		3.97	TAP1-21.50	TAK1-21.50	TAN1-21.50
1-C	21.60	0.8504		3.97	TAP1-21.60	TAK1-21.60	TAN1-21.60
1-C	21.70	0.8543		3.97	TAP1-21.70	TAK1-21.70	TAN1-21.70
1-C	21.80	0.8583		3.97	TAP1-21.80	TAK1-21.80	TAN1-21.80
1-C	21.83	0.8594	55/64	3.97	TAP1-21.83	TAK1-21.83	TAN1-21.83
1-C	21.90	0.8622		3.97	TAP1-21.90	TAK1-21.90	TAN1-21.90
1-C	22.00	0.8661		3.97	TAP1-22.00	TAK1-22.00	TAN1-22.00
1-C	22.10	0.8701		3.97	TAP1-22.10	TAK1-22.10	TAN1-22.10
1-C	22.20	0.8740		3.97	TAP1-22.20	TAK1-22.20	TAN1-22.20
1-C	22.23	0.8752	7/8	3.97	TAP1-22.23	TAK1-22.23	TAN1-22.23
1-C	22.30	0.8780		3.97	TAP1-22.30	TAK1-22.30	TAN1-22.30
1-C	22.40	0.8819		3.97	TAP1-22.40	TAK1-22.40	TAN1-22.40
1-C	22.50	0.8858		3.97	TAP1-22.50	TAK1-22.50	TAN1-22.50
1-C	22.62	0.8906	57/64	3.97	TAP1-22.62	TAK1-22.62	TAN1-22.62
1-C	22.70	0.8937		3.97	TAP1-22.70	TAK1-22.70	TAN1-22.70
1-C	22.80	0.8976		3.97	TAP1-22.80	TAK1-22.80	TAN1-22.80

Inserts sold in multiples of 2

Sub Series Holders (A, B, C, D)

Sub series holders are recommended when running carbide inserts toward the upper end of the series drill range, as well as in tougher applications requiring more insert support and holder strength. NOTE: Only specified sub series inserts should be used with equivalent or smaller sub series holders.

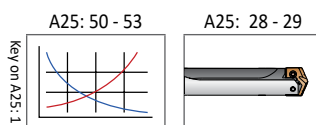
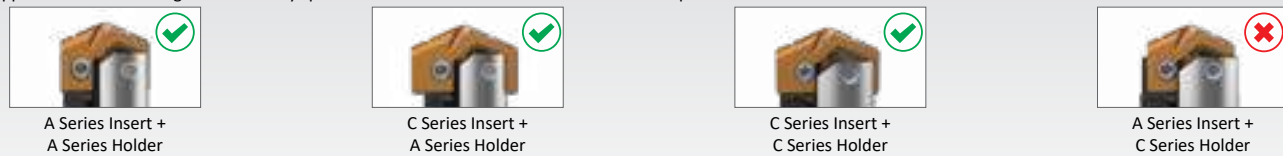

Sizes not shown are available upon request. When ordering, please follow the example below:
Metric: 13.16mm, Steel, 0 series = use Part No. **TAP0-13.16**
Imperial: 0.5180", Steel, 0 series = use Part No. **TAP0-13.16**

T-A Pro Carbide Drill Inserts

1 Series | Diameter Range: 17.65mm - 24.37mm

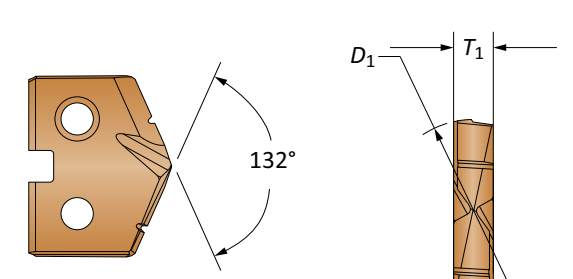

Series	Insert				Part No.		
	D ₁ mm	D ₁ inch	Fractional Equivalent	T ₁ mm	P	K	N
1-D	22.90	0.9016		3.97	TAP1-22.90	TAK1-22.90	TAN1-22.90
1-D	23.00	0.9055		3.97	TAP1-23.00	TAK1-23.00	TAN1-23.00
1-D	23.02	0.9063	29/32	3.97	TAP1-23.02	TAK1-23.02	TAN1-23.02
1-D	23.10	0.9094		3.97	TAP1-23.10	TAK1-23.10	TAN1-23.10
1-D	23.20	0.9134		3.97	TAP1-23.20	TAK1-23.20	TAN1-23.20
1-D	23.30	0.9173		3.97	TAP1-23.30	TAK1-23.30	TAN1-23.30
1-D	23.42	0.9220	59/64	3.97	TAP1-23.42	TAK1-23.42	TAN1-23.42
1-D	23.50	0.9252		3.97	TAP1-23.50	TAK1-23.50	TAN1-23.50
1-D	23.60	0.9291		3.97	TAP1-23.60	TAK1-23.60	TAN1-23.60
1-D	23.70	0.9331		3.97	TAP1-23.70	TAK1-23.70	TAN1-23.70
1-D	23.81	0.9374	15/16	3.97	TAP1-23.81	TAK1-23.81	TAN1-23.81
1-D	23.90	0.9409		3.97	TAP1-23.90	TAK1-23.90	TAN1-23.90
1-D	24.00	0.9449		3.97	TAP1-24.00	TAK1-24.00	TAN1-24.00
1-D	24.10	0.9488		3.97	TAP1-24.10	TAK1-24.10	TAN1-24.10
1-D	24.20	0.9528		3.97	TAP1-24.20	TAK1-24.20	TAN1-24.20
1-D	24.30	0.9567		3.97	TAP1-24.30	TAK1-24.30	TAN1-24.30

Inserts sold in multiples of 2

Sub Series Holders (A, B, C, D)

Sub series holders are recommended when running carbide inserts toward the upper end of the series drill range, as well as in tougher applications requiring more insert support and holder strength. NOTE: Only specified sub series inserts should be used with equivalent or smaller sub series holders.

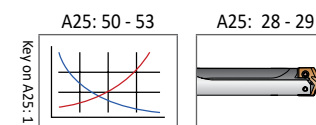
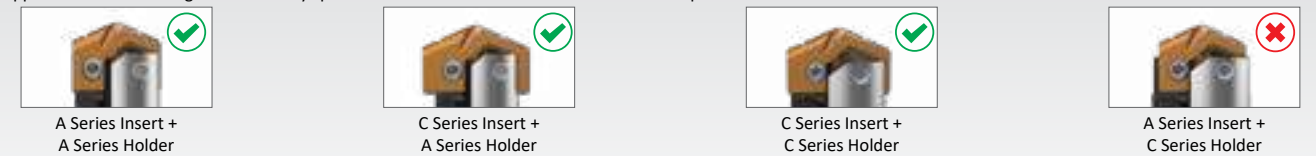

Sizes not shown are available upon request. When ordering, please follow the example below:
Metric: 13.16mm, Steel, 0 series = use Part No. **TAP0-13.16**
Imperial: 0.5180", Steel, 0 series = use Part No. **TAP0-13.16**

T-A Pro HSS Drill Inserts

1 Series | Diameter Range: 17.65mm - 24.37mm

T-A Pro HSS Drill Inserts

1 Series | Diameter Range: 17.65mm - 24.37mm

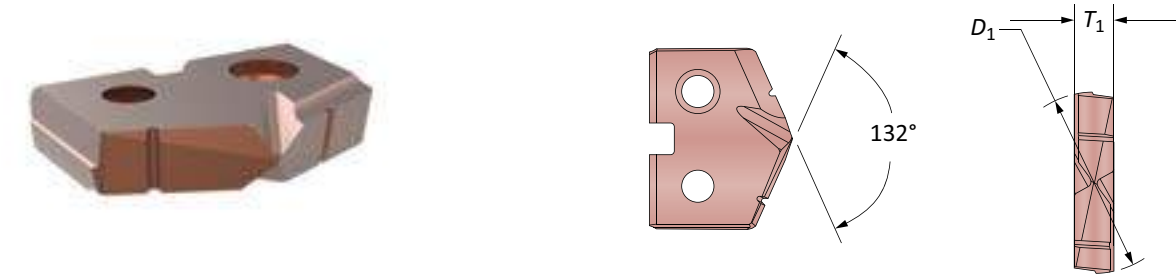
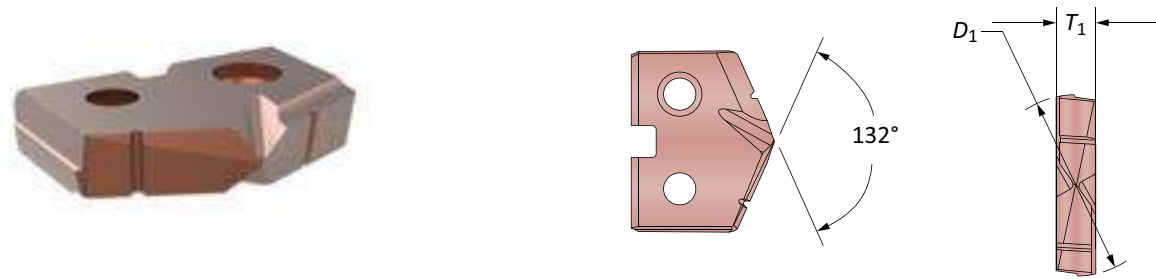

Series	Insert				Part No. X
	D ₁ mm	D ₁ inch	Fractional Equivalent	T ₁ mm	
1-A	17.70	0.6969		3.97	TAX1-17.70
1-A	17.80	0.7008		3.97	TAX1-17.80
1-A	17.86	0.7031	45/64	3.97	TAX1-17.86
1-A	17.90	0.7047		3.97	TAX1-17.90
1-A	18.00	0.7087		3.97	TAX1-18.00
1-A	18.10	0.7126		3.97	TAX1-18.10
1-A	18.20	0.7165		3.97	TAX1-18.20
1-A	18.26	0.7189	23/32	3.97	TAX1-18.26
1-A	18.30	0.7205		3.97	TAX1-18.30
1-A	18.40	0.7244		3.97	TAX1-18.40
1-A	18.50	0.7283		3.97	TAX1-18.50
1-A	18.60	0.7323		3.97	TAX1-18.60
1-A	18.65	0.7343	47/64	3.97	TAX1-18.65
1-A	18.70	0.7362		3.97	TAX1-18.70
1-A	18.80	0.7402		3.97	TAX1-18.80
1-A	18.90	0.7441		3.97	TAX1-18.90
1-A	19.00	0.7480		3.97	TAX1-19.00

Inserts sold in multiples of 2

Series	Insert				Part No. X
	D ₁ mm	D ₁ inch	Fractional Equivalent	T ₁ mm	
1-B	19.05	0.7500	3/4	3.97	TAX1-19.05
1-B	19.10	0.7520		3.97	TAX1-19.10
1-B	19.20	0.7559		3.97	TAX1-19.20
1-B	19.25	0.7579		3.97	TAX1-19.25
1-B	19.30	0.7598		3.97	TAX1-19.30
1-B	19.40	0.7638		3.97	TAX1-19.40
1-B	19.45	0.7657	49/64	3.97	TAX1-19.45
1-B	19.50	0.7677		3.97	TAX1-19.50
1-B	19.60	0.7717		3.97	TAX1-19.60
1-B	19.70	0.7756		3.97	TAX1-19.70
1-B	19.80	0.7795		3.97	TAX1-19.80
1-B	19.84	0.7811	25/32	3.97	TAX1-19.84
1-B	19.90	0.7835		3.97	TAX1-19.90
1-B	20.00	0.7874		3.97	TAX1-20.00
1-B	20.10	0.7913		3.97	TAX1-20.10
1-B	20.20	0.7953		3.97	TAX1-20.20
1-B	20.24	0.7969	51/64	3.97	TAX1-20.24
1-B	20.30	0.7992		3.97	TAX1-20.30
1-B	20.40	0.8031		3.97	TAX1-20.40
1-B	20.50	0.8071		3.97	TAX1-20.50

Inserts sold in multiples of 2

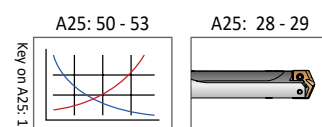

Sizes not shown are available upon request.
When ordering, please follow the example below:

Metric:	13.16mm, Steel, 0 series = use Part No. TAP0-13.16
Imperial:	0.5180", Steel, 0 series = use Part No. TAP0-13.16

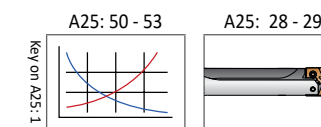

Sizes not shown are available upon request.
When ordering, please follow the example below:

Metric:	13.16mm, Steel, 0 series = use Part No. TAP0-13.16
Imperial:	0.5180", Steel, 0 series = use Part No. TAP0-13.16

T-A Pro HSS Drill Inserts

1 Series | Diameter Range: 17.65mm - 24.37mm

T-A Pro HSS Drill Inserts

1 Series | Diameter Range: 17.65mm - 24.37mm

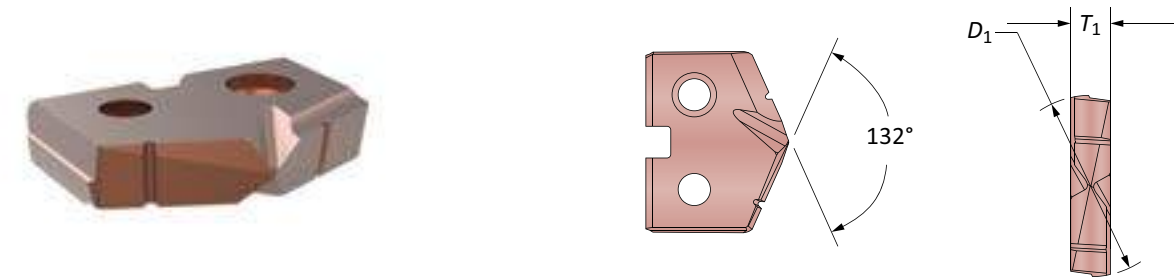
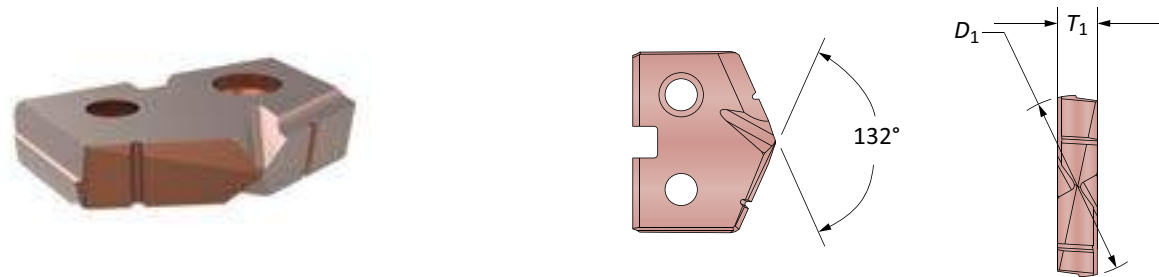

Series	Insert				Part No. X
	D ₁ mm	D ₁ inch	Fractional Equivalent	T ₁ mm	
1-C	20.60	0.8110		3.97	TAX1-20.60
1-C	20.64	0.8126	13/16	3.97	TAX1-20.64
1-C	20.70	0.8150		3.97	TAX1-20.70
1-C	20.80	0.8189		3.97	TAX1-20.80
1-C	20.90	0.8228		3.97	TAX1-20.90
1-C	21.00	0.8268		3.97	TAX1-21.00
1-C	21.10	0.8307		3.97	TAX1-21.10
1-C	21.20	0.8346		3.97	TAX1-21.20
1-C	21.30	0.8386		3.97	TAX1-21.30
1-C	21.40	0.8425		3.97	TAX1-21.40
1-C	21.43	0.8437	27/32	3.97	TAX1-21.43
1-C	21.50	0.8465		3.97	TAX1-21.50
1-C	21.60	0.8504		3.97	TAX1-21.60
1-C	21.70	0.8543		3.97	TAX1-21.70
1-C	21.80	0.8583		3.97	TAX1-21.80
1-C	21.83	0.8594	55/64	3.97	TAX1-21.83
1-C	21.90	0.8622		3.97	TAX1-21.90
1-C	22.00	0.8661		3.97	TAX1-22.00
1-C	22.10	0.8701		3.97	TAX1-22.10
1-C	22.20	0.8740		3.97	TAX1-22.20
1-C	22.23	0.8752	7/8	3.97	TAX1-22.23
1-C	22.30	0.8780		3.97	TAX1-22.30
1-C	22.40	0.8819		3.97	TAX1-22.40
1-C	22.50	0.8858		3.97	TAX1-22.50
1-C	22.62	0.8906	57/64	3.97	TAX1-22.62
1-C	22.70	0.8937		3.97	TAX1-22.70
1-C	22.80	0.8976		3.97	TAX1-22.80

Inserts sold in multiples of 2

Series	Insert				Part No. X
	D ₁ mm	D ₁ inch	Fractional Equivalent	T ₁ mm	
1-D	22.90	0.9016		3.97	TAX1-22.90
1-D	23.00	0.9055		3.97	TAX1-23.00
1-D	23.02	0.9063	29/32	3.97	TAX1-23.02
1-D	23.10	0.9094		3.97	TAX1-23.10
1-D	23.20	0.9134		3.97	TAX1-23.20
1-D	23.30	0.9173		3.97	TAX1-23.30
1-D	23.42	0.9220	59/64	3.97	TAX1-23.42
1-D	23.50	0.9252		3.97	TAX1-23.50
1-D	23.60	0.9291		3.97	TAX1-23.60
1-D	23.70	0.9331		3.97	TAX1-23.70
1-D	23.81	0.9374	15/16	3.97	TAX1-23.81
1-D	23.90	0.9409		3.97	TAX1-23.90
1-D	24.00	0.9449		3.97	TAX1-24.00
1-D	24.10	0.9488		3.97	TAX1-24.10
1-D	24.20	0.9528		3.97	TAX1-24.20
1-D	24.30	0.9567		3.97	TAX1-24.30

Inserts sold in multiples of 2

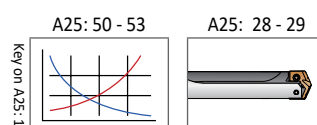

Sizes not shown are available upon request.
When ordering, please follow the example below:
Metric: 13.16mm, Steel, 0 series = use Part No. **TAP0-13.16**
Imperial: 0.5180", Steel, 0 series = use Part No. **TAP0-13.16**

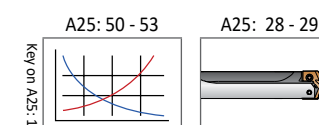

Sizes not shown are available upon request.
When ordering, please follow the example below:
Metric: 13.16mm, Steel, 0 series = use Part No. **TAP0-13.16**
Imperial: 0.5180", Steel, 0 series = use Part No. **TAP0-13.16**

T-A Pro Drill Holders

1 Series Metric | Diameter Range: 17.65mm - 24.37mm

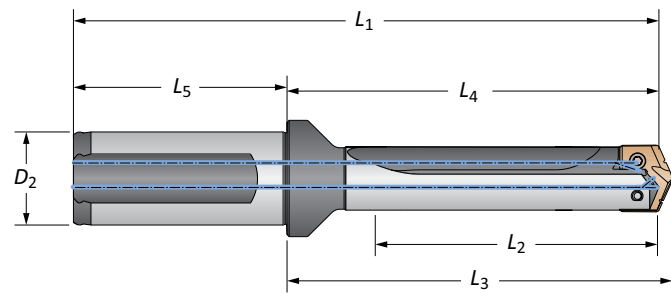

Length	Sub Series	Series Diameter	Body				Shank				Part No
			L ₂ mm	L ₄ mm	L ₃ mm	L ₁ mm	L ₅ mm	D ₂ mm	Flat		
STUB	A	17.70 - 19.00	21.0	56.5	60.0	114.4	57.9	25	Yes	HTA1A01-25FM	
STUB	A	17.70 - 19.00	21.0	56.5	60.0	114.4	57.9	25	No	HTA1A01-25CM	
STUB	B	19.05 - 20.50	21.0	56.5	60.0	114.4	57.9	25	Yes	HTA1B01-25FM	
STUB	B	19.05 - 20.50	21.0	56.5	60.0	114.4	57.9	25	No	HTA1B01-25CM	
STUB	C	20.60 - 22.80	21.0	56.5	60.0	114.4	57.9	25	Yes	HTA1C01-25FM	
STUB	C	20.60 - 22.80	21.0	56.5	60.0	114.4	57.9	25	No	HTA1C01-25CM	
STUB	D	22.90 - 24.30	21.0	56.5	60.0	114.4	57.9	25	Yes	HTA1D01-25FM	
STUB	D	22.90 - 24.30	21.0	56.5	60.0	114.4	57.9	25	No	HTA1D01-25CM	
3xD	A	17.70 - 19.00	62.9	100.9	104.5	158.8	57.9	25	Yes	HTA1A03-25FM	
3xD	A	17.70 - 19.00	62.9	100.9	104.5	158.8	57.9	25	No	HTA1A03-25CM	
3xD	B	19.05 - 20.50	62.9	100.9	104.5	158.8	57.9	25	Yes	HTA1B03-25FM	
3xD	B	19.05 - 20.50	62.9	100.9	104.5	158.8	57.9	25	No	HTA1B03-25CM	
3xD	C	20.60 - 22.80	62.9	100.9	104.5	158.8	57.9	25	Yes	HTA1C03-25FM	
3xD	C	20.60 - 22.80	62.9	100.9	104.5	158.8	57.9	25	No	HTA1C03-25CM	
3xD	D	22.90 - 24.30	62.9	100.9	104.5	158.8	57.9	25	Yes	HTA1D03-25FM	
3xD	D	22.90 - 24.30	62.9	100.9	104.5	158.8	57.9	25	No	HTA1D03-25CM	
5xD	A	17.70 - 19.00	104.8	142.8	146.4	200.7	57.9	25	Yes	HTA1A05-25FM	
5xD	A	17.70 - 19.00	104.8	142.8	146.4	200.7	57.9	25	No	HTA1A05-25CM	
5xD	B	19.05 - 20.50	104.8	142.8	146.4	200.7	57.9	25	Yes	HTA1B05-25FM	
5xD	B	19.05 - 20.50	104.8	142.8	146.4	200.7	57.9	25	No	HTA1B05-25CM	
5xD	C	20.60 - 22.80	104.8	142.8	146.4	200.7	57.9	25	Yes	HTA1C05-25FM	
5xD	C	20.60 - 22.80	104.8	142.8	146.4	200.7	57.9	25	No	HTA1C05-25CM	
5xD	D	22.90 - 24.30	104.8	142.8	146.4	200.7	57.9	25	Yes	HTA1D05-25FM	
5xD	D	22.90 - 24.30	104.8	142.8	146.4	200.7	57.9	25	No	HTA1D05-25CM	
7xD	A	17.70 - 19.00	146.7	184.7	188.3	242.7	57.9	25	Yes	HTA1A07-25FM	
7xD	A	17.70 - 19.00	146.7	184.7	188.3	242.7	57.9	25	No	HTA1A07-25CM	
7xD	B	19.05 - 20.50	146.7	184.7	188.3	242.7	57.9	25	Yes	HTA1B07-25FM	
7xD	B	19.05 - 20.50	146.7	184.7	188.3	242.7	57.9	25	No	HTA1B07-25CM	
7xD	C	20.60 - 22.80	146.7	184.7	188.3	242.7	57.9	25	Yes	HTA1C07-25FM	
7xD	C	20.60 - 22.80	146.7	184.7	188.3	242.7	57.9	25	No	HTA1C07-25CM	
7xD	D	22.90 - 24.30	146.7	184.7	188.3	242.7	57.9	25	Yes	HTA1D07-25FM	
7xD	D	22.90 - 24.30	146.7	184.7	188.3	242.7	57.9	25	No	HTA1D07-25CM	

Connection Accessories

	Insert Screws	Nylon Locking Screws	Insert Driver	Preset Torque Hand Driver	Replacement Tips	Admissible Tightening Torque*
A/B	7375-IP9-1	7375N-IP9-1	8IP-9	8IP-9TL	8IP-9B	305 N-cm (27.0 in-lbs)
C/D	739-IP9-1	739N-IP9-1	8IP-9	8IP-9TL	8IP-9B	305 N-cm (27.0 in-lbs)

*Tightening torques are calculated with a friction coefficient of $\mu = 0.14$ and develop 90% of ultimate yield strength

WARNING Refer to Speed and Feed charts for recommended adjustments to speeds and feeds. Refer to page A25: 54 for deep hole drilling guidelines in this section of the catalog. Visit www.alliedmachine.com/DeepHoleGuidelines for the most up-to-date information and procedures. Factory technical assistance is available for your specific applications through our Application Engineering department. Email: engineering.eu@alliedmachine.com



Ⓜ = Metric (mm)
Ⓢ = Imperial (in)
Screws sold in multiples of 10

T-A Pro Drill Holders

1 Series Metric | Diameter Range: 17.65mm - 24.37mm

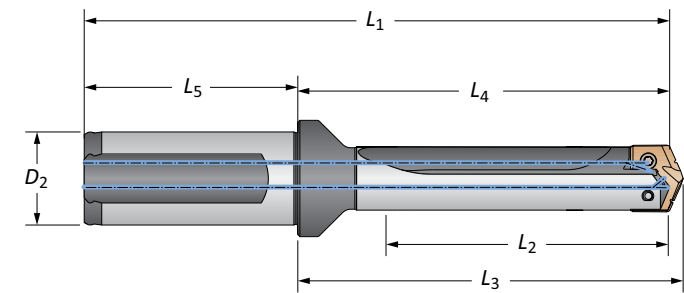

Length	Sub Series	Series Diameter	Body				Shank				Part No
			L ₂ mm	L ₄ mm	L ₃ mm	L ₁ mm	L ₅ mm	D ₂ mm	Flat		
10xD	A	17.70 - 19.00	209.6	247.6	251.2	305.5	57.9	25	Yes	HTA1A10-25FM	
10xD	A	17.70 - 19.00	209.6	247.6	251.2	305.5	57.9	25	No	HTA1A10-25CM	
10xD	B	19.05 - 20.50	209.6	247.6	251.2	305.5	57.9	25	Yes	HTA1B10-25FM	
10xD	B	19.05 - 20.50	209.6	247.6	251.2	305.5	57.9	25	No	HTA1B10-25CM	
10xD	C	20.60 - 22.80	209.6	247.6	251.2	305.5	57.9	25	Yes	HTA1C10-25FM	
10xD	C	20.60 - 22.80	209.6	247.6	251.2	305.5	57.9	25	No	HTA1C10-25CM	
10xD	D	22.90 - 24.30	209.6	247.6	251.2	305.5	57.9	25	Yes	HTA1D10-25FM	
10xD	D	22.90 - 24.30	209.6	247.6	251.2	305.5	57.9	25	No	HTA1D10-25CM	
12xD	A	17.70 - 19.00	251.5	289.5	293.1	347.4	57.9	25	Yes	HTA1A12-25FM	
12xD	A	17.70 - 19.00	251.5	289.5	293.1	347.4	57.9	25	No	HTA1A12-25CM	
12xD	B	19.05 - 20.50	251.5	289.5	293.1	347.4	57.9	25	Yes	HTA1B12-25FM	
12xD	B	19.05 - 20.50	251.5	289.5	293.1	347.4	57.9	25	No	HTA1B12-25CM	
12xD	C	20.60 - 22.80	251.5	289.5	293.1	347.4	57.9	25	Yes	HTA1C12-25FM	
12xD	C	20.60 - 22.80	251.5	289.5	293.1	347.4	57.9	25	No	HTA1C12-25CM	
12xD	D	22.90 - 24.30	251.5	289.5	293.1	347.4	57.9	25	Yes	HTA1D12-25FM	
12xD	D	22.90 - 24.30	251.5	289.5	293.1	347.4	57.9	25	No	HTA1D12-25CM	
15xD	A	17.70 - 19.00	314.3	352.4	355.9	410.3	57.9	25	Yes	HTA1A15-25FM	
15xD	A	17.70 - 19.00	314.3	352.4	355.9	410.3	57.9	25	No	HTA1A15-25CM	
15xD	B	19.05 - 20.50	314.3	352.4	355.9	410.3	57.9	25	Yes	HTA1B15-25FM	
15xD	B	19.05 - 20.50	314.3	352.4	355.9	410.3	57.9	25	No	HTA1B15-25CM	
15xD	C	20.60 - 22.80	314.3	352.4	355.9	410.3	57.9	25	Yes	HTA1C15-25FM	
15xD	C	20.60 - 22.80	314.3	352.4	355.9	410.3	57.9	25	No	HTA1C15-25CM	
15xD	D	22.90 - 24.30	314.3	352.4	355.9	410.3	57.9	25	Yes	HTA1D15-25FM	
15xD	D	22.90 - 24.30	314.3	352.4	355.9	410.3	57.9	25	No	HTA1D15-25CM	

Connection Accessories

	Insert Screws	Nylon Locking Screws	Insert Driver	Preset Torque Hand Driver	Replacement Tips	Admissible Tightening Torque*
A/B	7375-IP9-1	7375N-IP9-1	8IP-9	8IP-9TL	8IP-9B	305 N-cm (27.0 in-lbs)
C/D	739-IP9-1	739N-IP9-1	8IP-9	8IP-9TL	8IP-9B	305 N-cm (27.0 in-lbs)

*Tightening torques are calculated with a friction coefficient of $\mu = 0.14$ and develop 90% of ultimate yield strength

WARNING Refer to Speed and Feed charts for recommended adjustments to speeds and feeds. Refer to page A25: 54 for deep hole drilling guidelines in this section of the catalog. Visit www.alliedmachine.com/DeepHoleGuidelines for the most up-to-date information and procedures. Factory technical assistance is available for your specific applications through our Application Engineering department. Email: engineering.eu@alliedmachine.com



Ⓜ = Metric (mm)
Ⓢ = Imperial (in)
Screws sold in multiples of 10

T-A Pro Carbide Drill Inserts

2 Series | Diameter Range: 24.38mm - 35.04mm

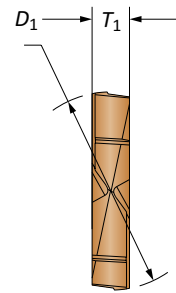
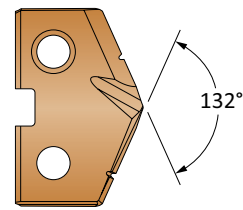

Series	Insert				Part No. P	Part No. K	Part No. N
	D ₁ mm	D ₁ inch	Fractional Equivalent	T ₁ mm			
2-A	24.40	0.9606		4.76	TAP2-24.40	TAK2-24.40	TAN2-24.40
2-A	24.50	0.9646		4.76	TAP2-24.50	TAK2-24.50	TAN2-24.50
2-A	24.61	0.9689	31/32	4.76	TAP2-24.61	TAK2-24.61	TAN2-24.61
2-A	24.70	0.9724		4.76	TAP2-24.70	TAK2-24.70	TAN2-24.70
2-A	24.80	0.9764		4.76	TAP2-24.80	TAK2-24.80	TAN2-24.80
2-A	24.90	0.9803		4.76	TAP2-24.90	TAK2-24.90	TAN2-24.90
2-A	25.00	0.9843	63/64	4.76	TAP2-25.00	TAK2-25.00	TAN2-25.00
2-A	25.10	0.9882		4.76	TAP2-25.10	TAK2-25.10	TAN2-25.10
2-A	25.20	0.9921		4.76	TAP2-25.20	TAK2-25.20	TAN2-25.20
2-A	25.30	0.9961		4.76	TAP2-25.30	TAK2-25.30	TAN2-25.30

Inserts sold in multiples of 2

Sub Series Holders (A, B, C, D)

Sub series holders are recommended when running carbide inserts toward the upper end of the series drill range, as well as in tougher applications requiring more insert support and holder strength. NOTE: Only specified sub series inserts should be used with equivalent or smaller sub series holders.



A Series Insert + A Series Holder

C Series Insert + A Series Holder

C Series Insert + C Series Holder

A Series Insert + C Series Holder

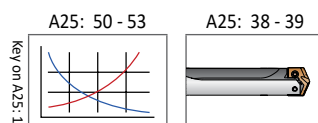

Sizes not shown are available upon request. When ordering, please follow the example below:
Metric: 13.16mm, Steel, 0 series = use Part No. **TAP0-13.16**
Imperial: 0.5180", Steel, 0 series = use Part No. **TAP0-13.16**

T-A Pro Carbide Drill Inserts

2 Series | Diameter Range: 24.38mm - 35.04mm

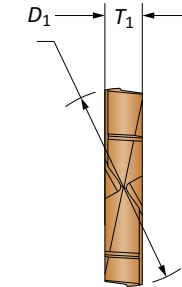
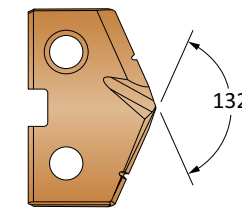

Series	Insert				Part No. P	Part No. K	Part No. N
	D ₁ mm	D ₁ inch	Fractional Equivalent	T ₁ mm			
2-B	25.40	1.0000	1	4.76	TAP2-25.40	TAK2-25.40	TAN2-25.40
2-B	25.50	1.0039		4.76	TAP2-25.50	TAK2-25.50	TAN2-25.50
2-B	25.60	1.0079		4.76	TAP2-25.60	TAK2-25.60	TAN2-25.60
2-B	25.70	1.0118		4.76	TAP2-25.70	TAK2-25.70	TAN2-25.70
2-B	25.78	1.0150		4.76	TAP2-25.78	TAK2-25.78	TAN2-25.78
2-B	25.90	1.0197		4.76	TAP2-25.90	TAK2-25.90	TAN2-25.90
2-B	26.00	1.0236		4.76	TAP2-26.00	TAK2-26.00	TAN2-26.00
2-B	26.10	1.0276		4.76	TAP2-26.10	TAK2-26.10	TAN2-26.10
2-B	26.20	1.0315	1-1/32	4.76	TAP2-26.20	TAK2-26.20	TAN2-26.20
2-B	26.30	1.0354		4.76	TAP2-26.30	TAK2-26.30	TAN2-26.30
2-B	26.40	1.0394		4.76	TAP2-26.40	TAK2-26.40	TAN2-26.40
2-B	26.50	1.0433		4.76	TAP2-26.50	TAK2-26.50	TAN2-26.50
2-B	26.57	1.0461		4.76	TAP2-26.57	TAK2-26.57	TAN2-26.57
2-B	26.59	1.0469	1-3/64	4.76	TAP2-26.59	TAK2-26.59	TAN2-26.59
2-B	26.60	1.0472		4.76	TAP2-26.60	TAK2-26.60	TAN2-26.60
2-B	26.70	1.0512		4.76	TAP2-26.70	TAK2-26.70	TAN2-26.70
2-B	26.80	1.0551		4.76	TAP2-26.80	TAK2-26.80	TAN2-26.80
2-B	26.90	1.0591		4.76	TAP2-26.90	TAK2-26.90	TAN2-26.90
2-B	26.99	1.0626	1-1/16	4.76	TAP2-26.99	TAK2-26.99	TAN2-26.99
2-B	27.00	1.0630		4.76	TAP2-27.00	TAK2-27.00	TAN2-27.00
2-B	27.10	1.0669		4.76	TAP2-27.10	TAK2-27.10	TAN2-27.10
2-B	27.20	1.0709		4.76	TAP2-27.20	TAK2-27.20	TAN2-27.20
2-B	27.30	1.0748		4.76	TAP2-27.30	TAK2-27.30	TAN2-27.30
2-B	27.40	1.0787		4.76	TAP2-27.40	TAK2-27.40	TAN2-27.40
2-B	27.50	1.0827		4.76	TAP2-27.50	TAK2-27.50	TAN2-27.50
2-B	27.60	1.0866		4.76	TAP2-27.60	TAK2-27.60	TAN2-27.60
2-B	27.70	1.0906		4.76	TAP2-27.70	TAK2-27.70	TAN2-27.70
2-B	27.78	1.0937	1-3/32	4.76	TAP2-27.78	TAK2-27.78	TAN2-27.78
2-B	27.90	1.0984		4.76	TAP2-27.90	TAK2-27.90	TAN2-27.90
2-B	28.00	1.1024		4.76	TAP2-28.00	TAK2-28.00	TAN2-28.00
2-B	28.10	1.1063		4.76	TAP2-28.10	TAK2-28.10	TAN2-28.10
2-B	28.17	1.1091	1-7/64	4.76	TAP2-28.17	TAK2-28.17	TAN2-28.17
2-B	28.20	1.1102		4.76	TAP2-28.20	TAK2-28.20	TAN2-28.20
2-B	28.30	1.1142		4.76	TAP2-28.30	TAK2-28.30	TAN2-28.30
2-B	28.40	1.1181		4.76	TAP2-28.40	TAK2-28.40	TAN2-28.40

Inserts sold in multiples of 2

Sub Series Holders (A, B, C, D)

Sub series holders are recommended when running carbide inserts toward the upper end of the series drill range, as well as in tougher applications requiring more insert support and holder strength. NOTE: Only specified sub series inserts should be used with equivalent or smaller sub series holders.



A Series Insert + A Series Holder

C Series Insert + A Series Holder

C Series Insert + C Series Holder

A Series Insert + C Series Holder

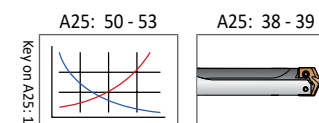

Sizes not shown are available upon request. When ordering, please follow the example below:
Metric: 13.16mm, Steel, 0 series = use Part No. **TAP0-13.16**
Imperial: 0.5180", Steel, 0 series = use Part No. **TAP0-13.16**

T-A Pro Carbide Drill Inserts

2 Series | Diameter Range: 24.38mm - 35.04mm

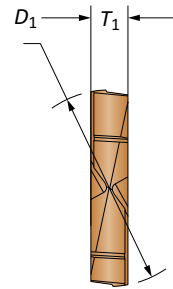
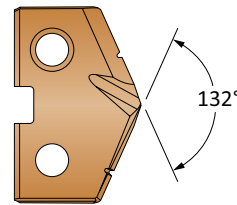

Series	Insert				Part No. P	Part No. K	Part No. N
	D ₁ mm	D ₁ inch	Fractional Equivalent	T ₁ mm			
2-C	28.50	1.1220	1-1/8	4.76	TAP2-28.50	TAK2-28.50	TAN2-28.50
2-C	28.58	1.1252		4.76	TAP2-28.58	TAK2-28.58	TAN2-28.58
2-C	28.70	1.1299		4.76	TAP2-28.70	TAK2-28.70	TAN2-28.70
2-C	28.80	1.1339		4.76	TAP2-28.80	TAK2-28.80	TAN2-28.80
2-C	28.90	1.1378	1-5/32	4.76	TAP2-28.90	TAK2-28.90	TAN2-28.90
2-C	29.00	1.1417		4.76	TAP2-29.00	TAK2-29.00	TAN2-29.00
2-C	29.10	1.1457		4.76	TAP2-29.10	TAK2-29.10	TAN2-29.10
2-C	29.20	1.1496		4.76	TAP2-29.20	TAK2-29.20	TAN2-29.20
2-C	29.30	1.1535	1-3/16	4.76	TAP2-29.30	TAK2-29.30	TAN2-29.30
2-C	29.37	1.1563		4.76	TAP2-29.37	TAK2-29.37	TAN2-29.37
2-C	29.40	1.1575		4.76	TAP2-29.40	TAK2-29.40	TAN2-29.40
2-C	29.50	1.1614		4.76	TAP2-29.50	TAK2-29.50	TAN2-29.50
2-C	29.60	1.1654	1-7/32	4.76	TAP2-29.60	TAK2-29.60	TAN2-29.60
2-C	29.70	1.1693		4.76	TAP2-29.70	TAK2-29.70	TAN2-29.70
2-C	29.80	1.1732		4.76	TAP2-29.80	TAK2-29.80	TAN2-29.80
2-C	29.90	1.1772		4.76	TAP2-29.90	TAK2-29.90	TAN2-29.90
2-C	30.00	1.1811	1-1/2	4.76	TAP2-30.00	TAK2-30.00	TAN2-30.00
2-C	30.10	1.1850		4.76	TAP2-30.10	TAK2-30.10	TAN2-30.10
2-C	30.16	1.1874		4.76	TAP2-30.16	TAK2-30.16	TAN2-30.16
2-C	30.20	1.1890		4.76	TAP2-30.20	TAK2-30.20	TAN2-30.20
2-C	30.30	1.1929	1-5/8	4.76	TAP2-30.30	TAK2-30.30	TAN2-30.30
2-C	30.40	1.1969		4.76	TAP2-30.40	TAK2-30.40	TAN2-30.40
2-C	30.50	1.2008		4.76	TAP2-30.50	TAK2-30.50	TAN2-30.50
2-C	30.60	1.2047		4.76	TAP2-30.60	TAK2-30.60	TAN2-30.60
2-C	30.70	1.2087	1-3/4	4.76	TAP2-30.70	TAK2-30.70	TAN2-30.70
2-C	30.80	1.2126		4.76	TAP2-30.80	TAK2-30.80	TAN2-30.80
2-C	30.90	1.2165		4.76	TAP2-30.90	TAK2-30.90	TAN2-30.90
2-C	30.96	1.2189		4.76	TAP2-30.96	TAK2-30.96	TAN2-30.96
2-C	31.00	1.2205	1-7/8	4.76	TAP2-31.00	TAK2-31.00	TAN2-31.00
2-C	31.10	1.2244		4.76	TAP2-31.10	TAK2-31.10	TAN2-31.10
2-C	31.20	1.2283		4.76	TAP2-31.20	TAK2-31.20	TAN2-31.20
2-C	31.30	1.2323		4.76	TAP2-31.30	TAK2-31.30	TAN2-31.30
2-C	31.40	1.2362	2	4.76	TAP2-31.40	TAK2-31.40	TAN2-31.40
2-C	31.50	1.2402		4.76	TAP2-31.50	TAK2-31.50	TAN2-31.50
2-C	31.60	1.2441		4.76	TAP2-31.60	TAK2-31.60	TAN2-31.60

Inserts sold in multiples of 2

Sub Series Holders (A, B, C, D)

Sub series holders are recommended when running carbide inserts toward the upper end of the series drill range, as well as in tougher applications requiring more insert support and holder strength.



A Series Insert + A Series Holder

C Series Insert + A Series Holder

C Series Insert + C Series Holder

A Series Insert + C Series Holder

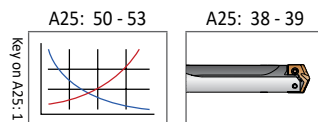

Sizes not shown are available upon request. When ordering, please follow the example below:
Metric: 13.16mm, Steel, 0 series = use Part No. **TAP0-13.16**
Imperial: 0.5180", Steel, 0 series = use Part No. **TAP0-13.16**

T-A Pro Carbide Drill Inserts

2 Series | Diameter Range: 24.38mm - 35.04mm

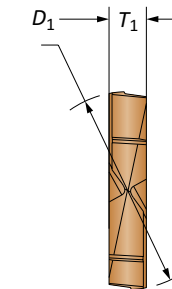
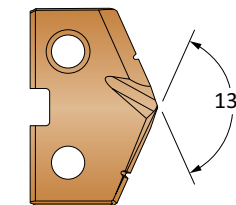

Series	Insert				Part No. P	Part No. K	Part No. N
	D ₁ mm	D ₁ inch	Fractional Equivalent	T ₁ mm			
2-D	31.70	1.2480	1-1/4	4.76	TAP2-31.70	TAK2-31.70	TAN2-31.70
2-D	31.75	1.2500		4.76	TAP2-31.75	TAK2-31.75	TAN2-31.75
2-D	31.80	1.2520		4.76	TAP2-31.80	TAK2-31.80	TAN2-31.80
2-D	31.90	1.2559		4.76	TAP2-31.90	TAK2-31.90	TAN2-31.90
2-D	32.00	1.2598	1-17/64	4.76	TAP2-32.00	TAK2-32.00	TAN2-32.00
2-D	32.10	1.2638		4.76	TAP2-32.10	TAK2-32.10	TAN2-32.10
2-D	32.15	1.2657		4.76	TAP2-32.15	TAK2-32.15	TAN2-32.15
2-D	32.20	1.2677		4.76	TAP2-32.20	TAK2-32.20	TAN2-32.20
2-D	32.30	1.2717	1-9/32	4.76	TAP2-32.30	TAK2-32.30	TAN2-32.30
2-D	32.40	1.2756		4.76	TAP2-32.40	TAK2-32.40	TAN2-32.40
2-D	32.50	1.2795		4.76	TAP2-32.50	TAK2-32.50	TAN2-32.50
2-D	32.55	1.2815		4.76	TAP2-32.55	TAK2-32.55	TAN2-32.55
2-D	32.60	1.2835	1-1/2	4.76	TAP2-32.60	TAK2-32.60	TAN2-32.60
2-D	32.70	1.2874		4.76	TAP2-32.70	TAK2-32.70	TAN2-32.70
2-D	32.80	1.2913		4.76	TAP2-32.80	TAK2-32.80	TAN2-32.80
2-D	32.90	1.2953		4.76	TAP2-32.90	TAK2-32.90	TAN2-32.90
2-D	33.00	1.2992	1-5/8	4.76	TAP2-33.00	TAK2-33.00	TAN2-33.00
2-D	33.10	1.3031		4.76	TAP2-33.10	TAK2-33.10	TAN2-33.10
2-D	33.20	1.3071		4.76	TAP2-33.20	TAK2-33.20	TAN2-33.20
2-D	33.30	1.3110		4.76	TAP2-33.30	TAK2-33.30	TAN2-33.30
2-D	33.34	1.3126	1-3/4	4.76	TAP2-33.34	TAK2-33.34	TAN2-33.34
2-D	33.40	1.3150		4.76	TAP2-33.40	TAK2-33.40	TAN2-33.40
2-D	33.50	1.3189		4.76	TAP2-33.50	TAK2-33.50	TAN2-33.50
2-D	33.60	1.3228		4.76	TAP2-33.60	TAK2-33.60	TAN2-33.60
2-D	33.70	1.3268	2	4.76	TAP2-33.70	TAK2-33.70	TAN2-33.70
2-D	33.80	1.3307		4.76	TAP2-33.80	TAK2-33.80	TAN2-33.80
2-D	33.90	1.3346		4.76	TAP2-33.90	TAK2-33.90	TAN2-33.90
2-D	34.00	1.3386		4.76	TAP2-34.00	TAK2-34.00	TAN2-34.00
2-D	34.10	1.3425	2-1/8	4.76	TAP2-34.10	TAK2-34.10	TAN2-34.10
2-D	34.13	1.3437		4.76	TAP2-34.13	TAK2-34.13	TAN2-34.13
2-D	34.20	1.3465		4.76	TAP2-34.20	TAK2-34.20	TAN2-34.20
2-D	34.30	1.3504		4.76	TAP2-34.30	TAK2-34.30	TAN2-34.30
2-D	34.40	1.3543	2-1/4	4.76	TAP2-34.40	TAK2-34.40	TAN2-34.40
2-D	34.50	1.3583		4.76	TAP2-34.50	TAK2-34.50	TAN2-34.50
2-D	34.60	1.3622		4.76	TAP2-34.60	TAK2-34.60	TAN2-34.60
2-D	34.70	1.3661		4.76	TAP2-34.70	TAK2-34.70	TAN2-34.70
2-D	34.80	1.3701	2-3/8	4.76	TAP2-34.80	TAK2-34.80	TAN2-34.80
2-D	34.90	1.3740		4.76	TAP2-34.90	TAK2-34.90	TAN2-34.90
2-D	34.93	1.3752		4.76	TAP2-34.93	TAK2-34.93	TAN2-34.93
2-D	35.00	1.3780		4.76	TAP2-35.00	TAK2-35.00	TAN2-35.00

Inserts sold in multiples of 2

Sub Series Holders (A, B, C, D)

Sub series holders are recommended when running carbide inserts toward the upper end of the series drill range, as well as in tougher applications requiring more insert support and holder strength. NOTE: Only specified sub series inserts should be used with equivalent or smaller sub series holders.



A Series Insert + A Series Holder

C Series Insert + A Series Holder

C Series Insert + C Series Holder

A Series Insert + C Series Holder

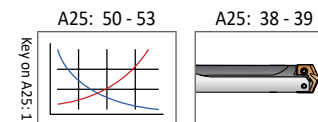

Sizes not shown are available upon request. When ordering, please follow the example below:
Metric: 13.16mm, Steel, 0 series = use Part No. **TAP0-13.16**
Imperial: 0.5180", Steel, 0 series = use Part No. **TAP0-13.16**

T-A Pro HSS Drill Inserts

2 Series | Diameter Range: 24.38mm - 35.04mm

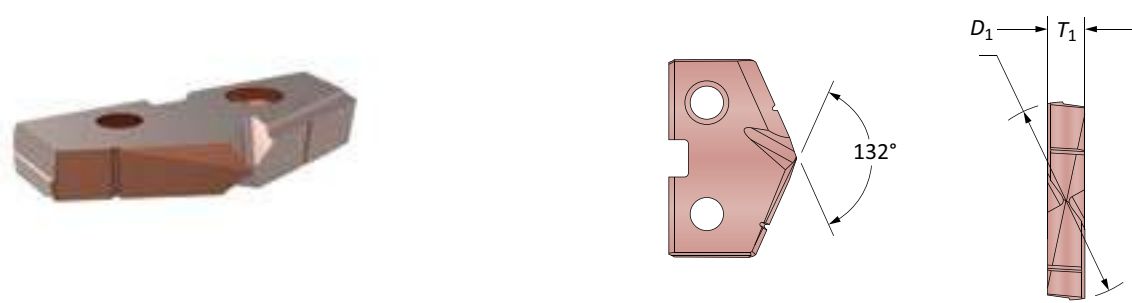

Series	Insert				Part No. X
	D ₁ mm	D ₁ inch	Fractional Equivalent	T ₁ mm	
2-A	24.40	0.9606		4.76	TAX2-24.40
2-A	24.50	0.9646		4.76	TAX2-24.50
2-A	24.61	0.9689	31/32	4.76	TAX2-24.61
2-A	24.70	0.9724		4.76	TAX2-24.70
2-A	24.80	0.9764		4.76	TAX2-24.80
2-A	24.90	0.9803		4.76	TAX2-24.90
2-A	25.00	0.9843	63/64	4.76	TAX2-25.00
2-A	25.10	0.9882		4.76	TAX2-25.10
2-A	25.20	0.9921		4.76	TAX2-25.20
2-A	25.30	0.9961		4.76	TAX2-25.30

Inserts sold in multiples of 2

T-A Pro HSS Drill Inserts

2 Series | Diameter Range: 24.38mm - 35.04mm

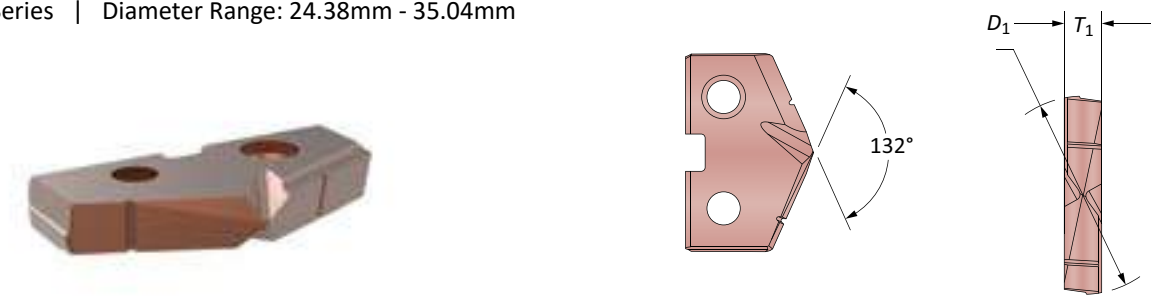

Series	Insert				Part No. X
	D ₁ mm	D ₁ inch	Fractional Equivalent	T ₁ mm	
2-B	25.40	1.0000	1	4.76	TAX2-25.40
2-B	25.50	1.0039		4.76	TAX2-25.50
2-B	25.60	1.0079		4.76	TAX2-25.60
2-B	25.70	1.0118		4.76	TAX2-25.70
2-B	25.78	1.0150		4.76	TAX2-25.78
2-B	25.90	1.0197		4.76	TAX2-25.90
2-B	26.00	1.0236		4.76	TAX2-26.00
2-B	26.10	1.0276		4.76	TAX2-26.10
2-B	26.20	1.0315	1-1/32	4.76	TAX2-26.20
2-B	26.30	1.0354		4.76	TAX2-26.30
2-B	26.40	1.0394		4.76	TAX2-26.40
2-B	26.50	1.0433		4.76	TAX2-26.50
2-B	26.57	1.0461		4.76	TAX2-26.57
2-B	26.59	1.0469	1-3/64	4.76	TAX2-26.59
2-B	26.60	1.0472		4.76	TAX2-26.60
2-B	26.70	1.0512		4.76	TAX2-26.70
2-B	26.80	1.0551		4.76	TAX2-26.80
2-B	26.90	1.0591		4.76	TAX2-26.90
2-B	26.99	1.0626	1-1/16	4.76	TAX2-26.99
2-B	27.00	1.0630		4.76	TAX2-27.00
2-B	27.10	1.0669		4.76	TAX2-27.10
2-B	27.20	1.0709		4.76	TAX2-27.20
2-B	27.30	1.0748		4.76	TAX2-27.30
2-B	27.40	1.0787		4.76	TAX2-27.40
2-B	27.50	1.0827		4.76	TAX2-27.50
2-B	27.60	1.0866		4.76	TAX2-27.60
2-B	27.70	1.0906		4.76	TAX2-27.70
2-B	27.78	1.0937	1-3/32	4.76	TAX2-27.78
2-B	27.90	1.0984		4.76	TAX2-27.90
2-B	28.00	1.1024		4.76	TAX2-28.00
2-B	28.10	1.1063		4.76	TAX2-28.10
2-B	28.17	1.1091	1-7/64	4.76	TAX2-28.17
2-B	28.20	1.1102		4.76	TAX2-28.20
2-B	28.30	1.1142		4.76	TAX2-28.30
2-B	28.40	1.1181		4.76	TAX2-28.40

Inserts sold in multiples of 2

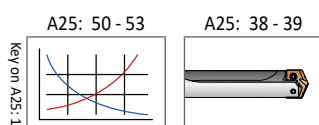

Sizes not shown are available upon request.
When ordering, please follow the example below:
Metric: 13.16mm, Steel, 0 series = use Part No. **TAP0-13.16**
Imperial: 0.5180", Steel, 0 series = use Part No. **TAP0-13.16**

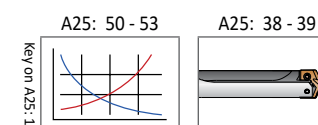

Sizes not shown are available upon request.
When ordering, please follow the example below:
Metric: 13.16mm, Steel, 0 series = use Part No. **TAP0-13.16**
Imperial: 0.5180", Steel, 0 series = use Part No. **TAP0-13.16**

T-A Pro HSS Drill Inserts

2 Series | Diameter Range: 24.38mm - 35.04mm

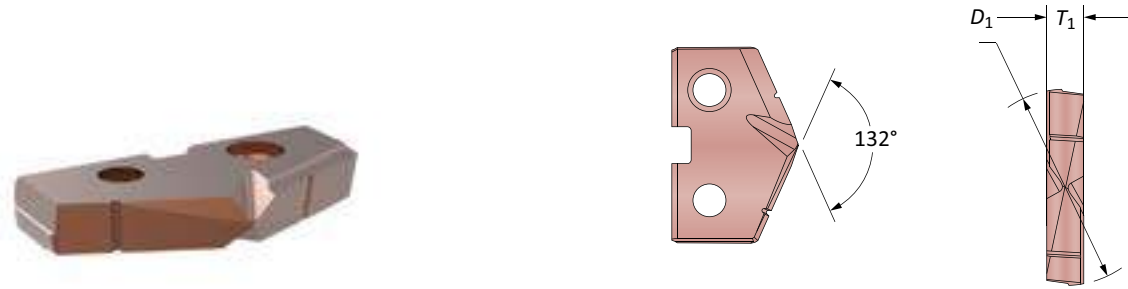

Series	Insert				Part No. X
	D ₁ mm	D ₁ inch	Fractional Equivalent	T ₁ mm	
2-C	28.50	1.1220		4.76	TAX2-28.50
2-C	28.58	1.1252	1-1/8	4.76	TAX2-28.58
2-C	28.70	1.1299		4.76	TAX2-28.70
2-C	28.80	1.1339		4.76	TAX2-28.80
2-C	28.90	1.1378		4.76	TAX2-28.90
2-C	29.00	1.1417		4.76	TAX2-29.00
2-C	29.10	1.1457		4.76	TAX2-29.10
2-C	29.20	1.1496		4.76	TAX2-29.20
2-C	29.30	1.1535		4.76	TAX2-29.30
2-C	29.37	1.1563	1-5/32	4.76	TAX2-29.37
2-C	29.40	1.1575		4.76	TAX2-29.40
2-C	29.50	1.1614		4.76	TAX2-29.50
2-C	29.60	1.1654		4.76	TAX2-29.60
2-C	29.70	1.1693		4.76	TAX2-29.70
2-C	29.80	1.1732		4.76	TAX2-29.80
2-C	29.90	1.1772		4.76	TAX2-29.90
2-C	30.00	1.1811		4.76	TAX2-30.00
2-C	30.10	1.1850		4.76	TAX2-30.10
2-C	30.16	1.1874	1-4/76	4.76	TAX2-30.16
2-C	30.20	1.1890		4.76	TAX2-30.20
2-C	30.30	1.1929		4.76	TAX2-30.30
2-C	30.40	1.1969		4.76	TAX2-30.40
2-C	30.50	1.2008		4.76	TAX2-30.50
2-C	30.60	1.2047		4.76	TAX2-30.60
2-C	30.70	1.2087		4.76	TAX2-30.70
2-C	30.80	1.2126		4.76	TAX2-30.80
2-C	30.90	1.2165		4.76	TAX2-30.90
2-C	30.96	1.2189	1-7/32	4.76	TAX2-30.96
2-C	31.00	1.2205		4.76	TAX2-31.00
2-C	31.10	1.2244		4.76	TAX2-31.10
2-C	31.20	1.2283		4.76	TAX2-31.20
2-C	31.30	1.2323		4.76	TAX2-31.30
2-C	31.40	1.2362		4.76	TAX2-31.40
2-C	31.50	1.2402		4.76	TAX2-31.50
2-C	31.60	1.2441		4.76	TAX2-31.60

Inserts sold in multiples of 2

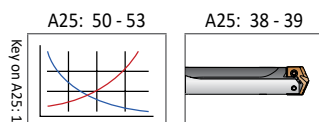

Sizes not shown are available upon request. When ordering, please follow the example below:	
Metric:	13.16mm, Steel, 0 series = use Part No. TAP0-13.16
Imperial:	0.5180", Steel, 0 series = use Part No. TAP0-13.16

T-A Pro HSS Drill Inserts

2 Series | Diameter Range: 24.38mm - 35.04mm

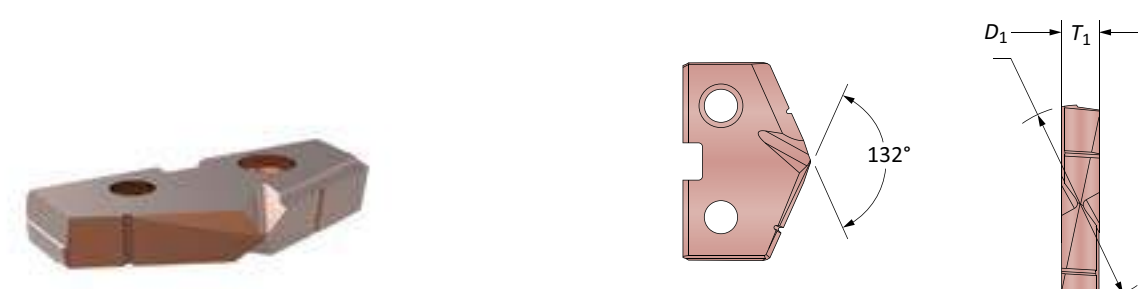

Series	Insert				Part No. X
	D ₁ mm	D ₁ inch	Fractional Equivalent	T ₁ mm	
2-D	31.70	1.2480		4.76	TAX2-31.70
2-D	31.75	1.2500	1-1/4	4.76	TAX2-31.75
2-D	31.80	1.2520		4.76	TAX2-31.80
2-D	31.90	1.2559		4.76	TAX2-31.90
2-D	32.00	1.2598		4.76	TAX2-32.00
2-D	32.10	1.2638		4.76	TAX2-32.10
2-D	32.15	1.2657	1-17/64	4.76	TAX2-32.15
2-D	32.20	1.2677		4.76	TAX2-32.20
2-D	32.30	1.2717		4.76	TAX2-32.30
2-D	32.40	1.2756		4.76	TAX2-32.40
2-D	32.50	1.2795		4.76	TAX2-32.50
2-D	32.55	1.2815	1-9/32	4.76	TAX2-32.55
2-D	32.60	1.2835		4.76	TAX2-32.60
2-D	32.70	1.2874		4.76	TAX2-32.70
2-D	32.80	1.2913		4.76	TAX2-32.80
2-D	32.90	1.2953		4.76	TAX2-32.90
2-D	33.00	1.2992		4.76	TAX2-33.00
2-D	33.10	1.3031		4.76	TAX2-33.10
2-D	33.20	1.3071		4.76	TAX2-33.20
2-D	33.30	1.3110		4.76	TAX2-33.30
2-D	33.34	1.3126	1-5/16	4.76	TAX2-33.34
2-D	33.40	1.3150		4.76	TAX2-33.40
2-D	33.50	1.3189		4.76	TAX2-33.50
2-D	33.60	1.3228		4.76	TAX2-33.60
2-D	33.70	1.3268		4.76	TAX2-33.70
2-D	33.80	1.3307		4.76	TAX2-33.80
2-D	33.90	1.3346		4.76	TAX2-33.90
2-D	34.00	1.3386		4.76	TAX2-34.00
2-D	34.10	1.3425		4.76	TAX2-34.10
2-D	34.13	1.3437	1-11/32	4.76	TAX2-34.13
2-D	34.20	1.3465		4.76	TAX2-34.20
2-D	34.30	1.3504		4.76	TAX2-34.30
2-D	34.40	1.3543		4.76	TAX2-34.40
2-D	34.50	1.3583		4.76	TAX2-34.50
2-D	34.60	1.3622		4.76	TAX2-34.60
2-D	34.70	1.3661		4.76	TAX2-34.70
2-D	34.80	1.3701		4.76	TAX2-34.80
2-D	34.90	1.3740		4.76	TAX2-34.90
2-D	34.93	1.3752	1-3/8	4.76	TAX2-34.93
2-D	35.00	1.3780		4.76	TAX2-35.00

Inserts sold in multiples of 2

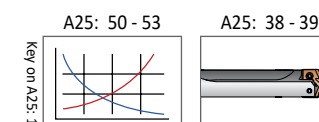

Sizes not shown are available upon request. When ordering, please follow the example below:	
Metric:	13.16mm, Steel, 0 series = use Part No. TAP0-13.16
Imperial:	0.5180", Steel, 0 series = use Part No. TAP0-13.16

T-A Pro Drill Holders

2 Series Metric | Diameter Range: 24.38mm - 35.04mm

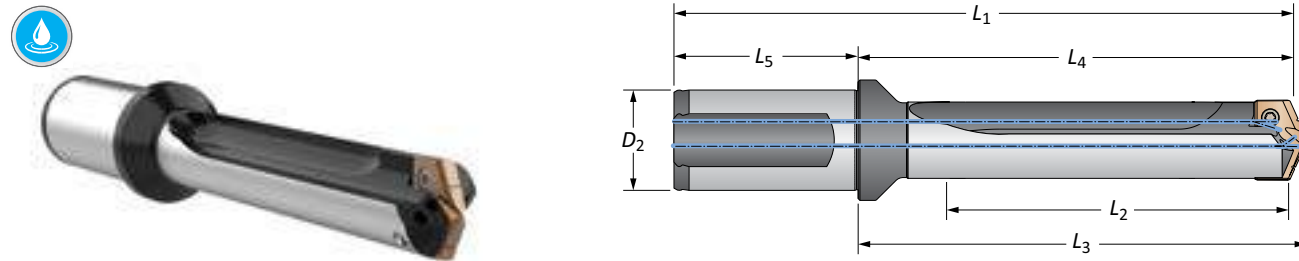

Length	Sub Series	Series Diameter	Body				Shank			Flat	Part No
			L ₂ mm	L ₄ mm	L ₃ mm	L ₁ mm	L ₅ mm	D ₂ mm			
STUB	A	24.40 - 25.30	29.7	75.0	78.6	132.9	57.9	32	Yes	HTA2A01-32FM	
STUB	A	24.40 - 25.30	29.7	75.0	78.6	132.9	57.9	32	No	HTA2A01-32CM	
STUB	B	25.40 - 28.40	29.7	75.0	78.6	132.9	57.9	32	Yes	HTA2B01-32FM	
STUB	B	25.40 - 28.40	29.7	75.0	78.6	132.9	57.9	32	No	HTA2B01-32CM	
STUB	C	28.50 - 31.60	29.7	75.0	78.6	132.9	57.9	32	Yes	HTA2C01-32FM	
STUB	C	28.50 - 31.60	29.7	75.0	78.6	132.9	57.9	32	No	HTA2C01-32CM	
STUB	D	31.70 - 35.00	29.7	75.0	78.6	132.9	57.9	32	Yes	HTA2D01-32FM	
STUB	D	31.70 - 35.00	29.7	75.0	78.6	132.9	57.9	32	No	HTA2D01-32CM	
3xD	A	24.40 - 25.30	89.2	137.4	141.0	195.4	57.9	32	Yes	HTA2A03-32FM	
3xD	A	24.40 - 25.30	89.2	137.4	141.0	195.4	57.9	32	No	HTA2A03-32CM	
3xD	B	25.40 - 28.40	89.2	137.4	141.0	195.4	57.9	32	Yes	HTA2B03-32FM	
3xD	B	25.40 - 28.40	89.2	137.4	141.0	195.4	57.9	32	No	HTA2B03-32CM	
3xD	C	28.50 - 31.60	89.2	137.4	141.0	195.4	57.9	32	Yes	HTA2C03-32FM	
3xD	C	28.50 - 31.60	89.2	137.4	141.0	195.4	57.9	32	No	HTA2C03-32CM	
3xD	D	31.70 - 35.00	89.2	137.4	141.0	195.4	57.9	32	Yes	HTA2D03-32FM	
3xD	D	31.70 - 35.00	89.2	137.4	141.0	195.4	57.9	32	No	HTA2D03-32CM	
5xD	A	24.40 - 25.30	148.7	196.9	200.5	254.8	57.9	32	Yes	HTA2A05-32FM	
5xD	A	24.40 - 25.30	148.7	196.9	200.5	254.8	57.9	32	No	HTA2A05-32CM	
5xD	B	25.40 - 28.40	148.7	196.9	200.5	254.8	57.9	32	Yes	HTA2B05-32FM	
5xD	B	25.40 - 28.40	148.7	196.9	200.5	254.8	57.9	32	No	HTA2B05-32CM	
5xD	C	28.50 - 31.60	148.7	196.9	200.5	254.8	57.9	32	Yes	HTA2C05-32FM	
5xD	C	28.50 - 31.60	148.7	196.9	200.5	254.8	57.9	32	No	HTA2C05-32CM	
5xD	D	31.70 - 35.00	148.7	196.9	200.5	254.8	57.9	32	Yes	HTA2D05-32FM	
5xD	D	31.70 - 35.00	148.7	196.9	200.5	254.8	57.9	32	No	HTA2D05-32CM	
7xD	A	24.40 - 25.30	208.2	256.4	260.0	314.3	57.9	32	Yes	HTA2A07-32FM	
7xD	A	24.40 - 25.30	208.2	256.4	260.0	314.3	57.9	32	No	HTA2A07-32CM	
7xD	B	25.40 - 28.40	208.2	256.4	260.0	314.3	57.9	32	Yes	HTA2B07-32FM	
7xD	B	25.40 - 28.40	208.2	256.4	260.0	314.3	57.9	32	No	HTA2B07-32CM	
7xD	C	28.50 - 31.60	208.2	256.4	260.0	314.3	57.9	32	Yes	HTA2C07-32FM	
7xD	C	28.50 - 31.60	208.2	256.4	260.0	314.3	57.9	32	No	HTA2C07-32CM	
7xD	D	31.70 - 35.00	208.2	256.4	260.0	314.3	57.9	32	Yes	HTA2D07-32FM	
7xD	D	31.70 - 35.00	208.2	256.4	260.0	314.3	57.9	32	No	HTA2D07-32CM	

Connection Accessories

					Admissible Tightening Torque*
7495-IP15-1	7495N-IP15-1	8IP-15	8IP-15TL	8IP-15B	

WARNING Refer to Speed and Feed charts for recommended adjustments to speeds and feeds. Refer to page A25: 54 for deep hole drilling guidelines in this section of the catalog. Visit www.alliedmachine.com/DeepHoleGuidelines for the most up-to-date information and procedures. Factory technical assistance is available for your specific applications through our Application Engineering department. Email: engineering.eu@alliedmachine.com



Ⓜ = Metric (mm)
 ⓘ = Imperial (in)
 Screws sold in multiples of 10

T-A Pro Drill Holders

2 Series Metric | Diameter Range: 24.38mm - 35.04mm

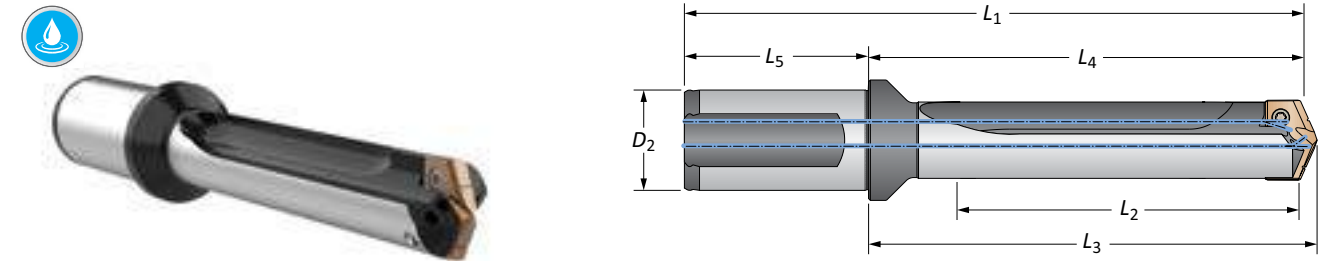

Length	Sub Series	Series Diameter	Body				Shank			Flat	Part No
			L ₂ mm	L ₄ mm	L ₃ mm	L ₁ mm	L ₅ mm	D ₂ mm			
10xD	A	24.40 - 25.30	297.4	345.6	349.2	403.6	57.9	32	Yes	HTA2A10-32FM	
10xD	A	24.40 - 25.30	297.4	345.6	349.2	403.6	57.9	32	No	HTA2A10-32CM	
10xD	B	25.40 - 28.40	297.4	345.6	349.2	403.6	57.9	32	Yes	HTA2B10-32FM	
10xD	B	25.40 - 28.40	297.4	345.6	349.2	403.6	57.9	32	No	HTA2B10-32CM	
10xD	C	28.50 - 31.60	297.4	345.6	349.2	403.6	57.9	32	Yes	HTA2C10-32FM	
10xD	C	28.50 - 31.60	297.4	345.6	349.2	403.6	57.9	32	No	HTA2C10-32CM	
10xD	D	31.70 - 35.00	297.4	345.6	349.2	403.6	57.9	32	Yes	HTA2D10-32FM	
10xD	D	31.70 - 35.00	297.4	345.6	349.2	403.6	57.9	32	No	HTA2D10-32CM	
12xD	A	24.40 - 25.30	356.9	405.1	408.7	463.0	57.9	32	Yes	HTA2A12-32FM	
12xD	A	24.40 - 25.30	356.9	405.1	408.7	463.0	57.9	32	No	HTA2A12-32CM	
12xD	B	25.40 - 28.40	356.9	405.1	408.7	463.0	57.9	32	Yes	HTA2B12-32FM	
12xD	B	25.40 - 28.40	356.9	405.1	408.7	463.0	57.9	32	No	HTA2B12-32CM	
12xD	C	28.50 - 31.60	356.9	405.1	408.7	463.0	57.9	32	Yes	HTA2C12-32FM	
12xD	C	28.50 - 31.60	356.9	405.1	408.7	463.0	57.9	32	No	HTA2C12-32CM	
12xD	D	31.70 - 35.00	356.9	405.1	408.7	463.0	57.9	32	Yes	HTA2D12-32FM	
12xD	D	31.70 - 35.00	356.9	405.1	408.7	463.0	57.9	32	No	HTA2D12-32CM	
15xD	A	24.40 - 25.30	446.2	494.4	497.9	552.3	57.9	32	Yes	HTA2A15-32FM	
15xD	A	24.40 - 25.30	446.2	494.4	497.9	552.3	57.9	32	No	HTA2A15-32CM	
15xD	B	25.40 - 28.40	446.2	494.4	497.9	552.3	57.9	32	Yes	HTA2B15-32FM	
15xD	B	25.40 - 28.40	446.2	494.4	497.9	552.3	57.9	32	No	HTA2B15-32CM	
15xD	C	28.50 - 31.60	446.2	494.4	497.9	552.3	57.9	32	Yes	HTA2C15-32FM	
15xD	C	28.50 - 31.60	446.2	494.4	497.9	552.3	57.9	32	No	HTA2C15-32CM	
15xD	D	31.70 - 35.00	446.2	494.4	497.9	552.3	57.9	32	Yes	HTA2D15-32FM	
15xD	D	31.70 - 35.00	446.2	494.4	497.9	552.3	57.9	32	No	HTA2D15-32CM	

Connection Accessories

					Admissible Tightening Torque*
7495-IP15-1	7495N-IP15-1	8IP-15	8IP-15TL	8IP-15B	

WARNING Refer to Speed and Feed charts for recommended adjustments to speeds and feeds. Refer to page A25: 54 for deep hole drilling guidelines in this section of the catalog. Visit www.alliedmachine.com/DeepHoleGuidelines for the most up-to-date information and procedures. Factory technical assistance is available for your specific applications through our Application Engineering department. Email: engineering.eu@alliedmachine.com



Ⓜ = Metric (mm)
 ⓘ = Imperial (in)
 Screws sold in multiples of 10

T-A Pro Carbide Drill Inserts

3 Series | Diameter Range: 35.05mm - 47.80mm

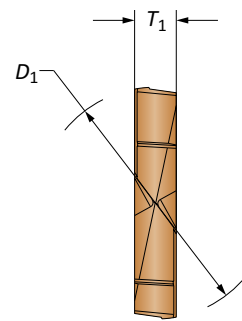
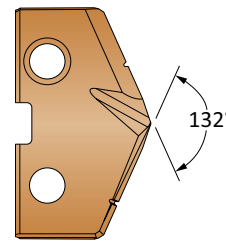

Series	Insert				Part No.	Part No.	Part No.
	D ₁ mm	D ₁ inch	Fractional Equivalent	T ₁ mm			
3-A	35.72	1.4063	1-13/32	6.35	TAP3-35.72	TAK3-35.72	TAN3-35.72
3-A	35.80	1.4094		6.35	TAP3-35.80	TAK3-35.80	TAN3-35.80
3-A	35.90	1.4134		6.35	TAP3-35.90	TAK3-35.90	TAN3-35.90
3-A	36.00	1.4173		6.35	TAP3-36.00	TAK3-36.00	TAN3-36.00
3-A	36.10	1.4213		6.35	TAP3-36.10	TAK3-36.10	TAN3-36.10
3-A	36.20	1.4252		6.35	TAP3-36.20	TAK3-36.20	TAN3-36.20
3-A	36.30	1.4291		6.35	TAP3-36.30	TAK3-36.30	TAN3-36.30
3-A	36.40	1.4331		6.35	TAP3-36.40	TAK3-36.40	TAN3-36.40
3-A	36.50	1.4370		6.35	TAP3-36.50	TAK3-36.50	TAN3-36.50
3-A	36.51	1.4374	1-7/16	6.35	TAP3-36.51	TAK3-36.51	TAN3-36.51
3-A	36.60	1.4409		6.35	TAP3-36.60	TAK3-36.60	TAN3-36.60
3-A	36.70	1.4449		6.35	TAP3-36.70	TAK3-36.70	TAN3-36.70
3-A	36.80	1.4488		6.35	TAP3-36.80	TAK3-36.80	TAN3-36.80
3-A	36.90	1.4528		6.35	TAP3-36.90	TAK3-36.90	TAN3-36.90
3-A	37.00	1.4567		6.35	TAP3-37.00	TAK3-37.00	TAN3-37.00
3-A	37.10	1.4606		6.35	TAP3-37.10	TAK3-37.10	TAN3-37.10
3-A	37.20	1.4646		6.35	TAP3-37.20	TAK3-37.20	TAN3-37.20
3-A	37.30	1.4685		6.35	TAP3-37.30	TAK3-37.30	TAN3-37.30
3-A	37.31	1.4689	1-15/32	6.35	TAP3-37.31	TAK3-37.31	TAN3-37.31
3-A	37.40	1.4724		6.35	TAP3-37.40	TAK3-37.40	TAN3-37.40
3-A	37.50	1.4764		6.35	TAP3-37.50	TAK3-37.50	TAN3-37.50
3-A	37.60	1.4803		6.35	TAP3-37.60	TAK3-37.60	TAN3-37.60
3-A	37.70	1.4843		6.35	TAP3-37.70	TAK3-37.70	TAN3-37.70

Inserts sold in multiples of 1

Sub Series Holders (A, B, C, D)

Sub series holders are recommended when running carbide inserts toward the upper end of the series drill range, as well as in tougher applications requiring more insert support and holder strength.



A Series Insert + A Series Holder

C Series Insert + A Series Holder

C Series Insert + C Series Holder

A Series Insert + C Series Holder

A25: 50 - 53

A25: 48 - 49

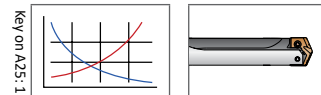

Sizes not shown are available upon request. When ordering, please follow the example below:

Metric:	13.16mm, Steel, 0 series = use Part No. TAP0-13.16
Imperial:	0.5180", Steel, 0 series = use Part No. TAP0-13.16

T-A Pro Carbide Drill Inserts

3 Series | Diameter Range: 35.05mm - 47.80mm

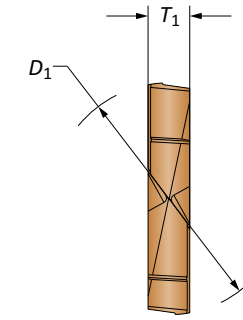
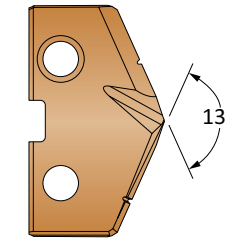
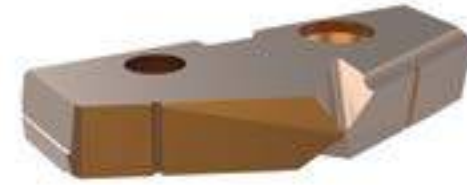

Series	Insert				Part No.	Part No.	Part No.
	D ₁ mm	D ₁ inch	Fractional Equivalent	T ₁ mm			
3-B	37.80	1.4882		6.35	TAP3-37.80	TAK3-37.80	TAN3-37.80
3-B	37.90	1.4921		6.35	TAP3-37.90	TAK3-37.90	TAN3-37.90
3-B	38.00	1.4961		6.35	TAP3-38.00	TAK3-38.00	TAN3-38.00
3-B	38.10	1.5000	1-1/2	6.35	TAP3-38.10	TAK3-38.10	TAN3-38.10
3-B	38.20	1.5039		6.35	TAP3-38.20	TAK3-38.20	TAN3-38.20
3-B	38.30	1.5079		6.35	TAP3-38.30	TAK3-38.30	TAN3-38.30
3-B	38.40	1.5118		6.35	TAP3-38.40	TAK3-38.40	TAN3-38.40
3-B	38.50	1.5157		6.35	TAP3-38.50	TAK3-38.50	TAN3-38.50
3-B	38.60	1.5197		6.35	TAP3-38.60	TAK3-38.60	TAN3-38.60
3-B	38.70	1.5236		6.35	TAP3-38.70	TAK3-38.70	TAN3-38.70
3-B	38.80	1.5276		6.35	TAP3-38.80	TAK3-38.80	TAN3-38.80
3-B	38.89	1.5311	1-17/32	6.35	TAP3-38.89	TAK3-38.89	TAN3-38.89
3-B	38.90	1.5315		6.35	TAP3-38.90	TAK3-38.90	TAN3-38.90
3-B	39.00	1.5354		6.35	TAP3-39.00	TAK3-39.00	TAN3-39.00
3-B	39.10	1.5394		6.35	TAP3-39.10	TAK3-39.10	TAN3-39.10
3-B	39.20	1.5433		6.35	TAP3-39.20	TAK3-39.20	TAN3-39.20
3-B	39.29	1.5469		6.35	TAP3-39.29	TAK3-39.29	TAN3-39.29
3-B	39.30	1.5472		6.35	TAP3-39.30	TAK3-39.30	TAN3-39.30
3-B	39.40	1.5512		6.35	TAP3-39.40	TAK3-39.40	TAN3-39.40
3-B	39.50	1.5551		6.35	TAP3-39.50	TAK3-39.50	TAN3-39.50
3-B	39.60	1.5591		6.35	TAP3-39.60	TAK3-39.60	TAN3-39.60
3-B	39.69	1.5626	1-9/16	6.35	TAP3-39.69	TAK3-39.69	TAN3-39.69
3-B	39.70	1.5630		6.35	TAP3-39.70	TAK3-39.70	TAN3-39.70
3-B	39.80	1.5669		6.35	TAP3-39.80	TAK3-39.80	TAN3-39.80
3-B	39.90	1.5709		6.35	TAP3-39.90	TAK3-39.90	TAN3-39.90
3-B	40.00	1.5748		6.35	TAP3-40.00	TAK3-40.00	TAN3-40.00
3-B	40.10	1.5787		6.35	TAP3-40.10	TAK3-40.10	TAN3-40.10
3-B	40.20	1.5827		6.35	TAP3-40.20	TAK3-40.20	TAN3-40.20
3-B	40.30	1.5866		6.35	TAP3-40.30	TAK3-40.30	TAN3-40.30
3-B	40.40	1.5906		6.35	TAP3-40.40	TAK3-40.40	TAN3-40.40
3-B	40.48	1.5937	1-19/32	6.35	TAP3-40.48	TAK3-40.48	TAN3-40.48
3-B	40.50	1.5945		6.35	TAP3-40.50	TAK3-40.50	TAN3-40.50
3-B	40.60	1.5984		6.35	TAP3-40.60	TAK3-40.60	TAN3-40.60
3-B	40.70	1.6024		6.35	TAP3-40.70	TAK3-40.70	TAN3-40.70
3-B	40.80	1.6063		6.35	TAP3-40.80	TAK3-40.80	TAN3-40.80
3-B	40.90	1.6102		6.35	TAP3-40.90	TAK3-40.90	TAN3-40.90

Inserts sold in multiples of 1

Sub Series Holders (A, B, C, D)

Sub series holders are recommended when running carbide inserts toward the upper end of the series drill range, as well as in tougher applications requiring more insert support and holder strength. NOTE: Only specified sub series inserts should be used with equivalent or smaller sub series holders.



A Series Insert + A Series Holder

C Series Insert + A Series Holder

C Series Insert + C Series Holder

A Series Insert + C Series Holder

A25: 50 - 53

A25: 48 - 49

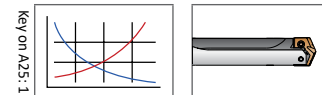

Sizes not shown are available upon request. When ordering, please follow the example below:

Metric:	13.16mm, Steel, 0 series = use Part No. TAP0-13.16
Imperial:	0.5180", Steel, 0 series = use Part No. TAP0-13.16

T-A Pro Carbide Drill Inserts

3 Series | Diameter Range: 35.05mm - 47.80mm

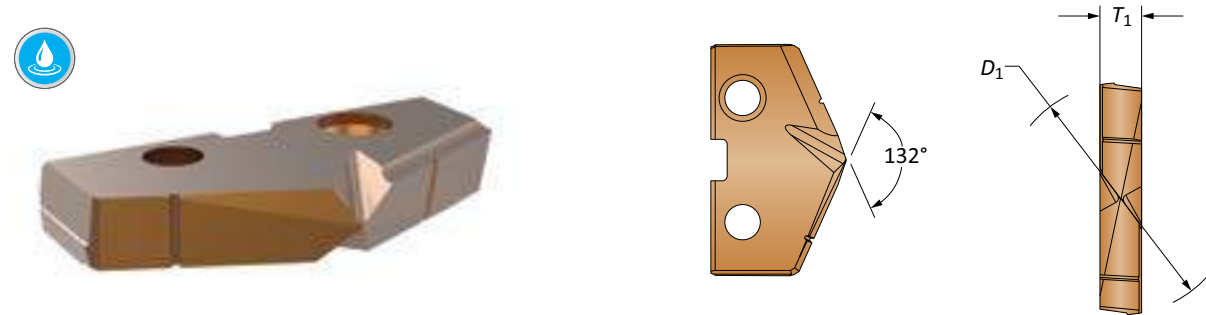

Series	Insert				Part No. P	Part No. K	Part No. N
	D ₁ mm	D ₁ inch	Fractional Equivalent	T ₁ mm			
3-C	41.00	1.6142		6.35	TAP3-41.00	TAK3-41.00	TAN3-41.00
3-C	41.10	1.6181		6.35	TAP3-41.10	TAK3-41.10	TAN3-41.10
3-C	41.20	1.6220		6.35	TAP3-41.20	TAK3-41.20	TAN3-41.20
3-C	41.28	1.6252	1-5/8	6.35	TAP3-41.28	TAK3-41.28	TAN3-41.28
3-C	41.30	1.6260		6.35	TAP3-41.30	TAK3-41.30	TAN3-41.30
3-C	41.40	1.6299		6.35	TAP3-41.40	TAK3-41.40	TAN3-41.40
3-C	41.50	1.6339		6.35	TAP3-41.50	TAK3-41.50	TAN3-41.50
3-C	41.60	1.6378		6.35	TAP3-41.60	TAK3-41.60	TAN3-41.60
3-C	41.70	1.6417		6.35	TAP3-41.70	TAK3-41.70	TAN3-41.70
3-C	41.80	1.6457		6.35	TAP3-41.80	TAK3-41.80	TAN3-41.80
3-C	41.90	1.6496		6.35	TAP3-41.90	TAK3-41.90	TAN3-41.90
3-C	42.00	1.6535		6.35	TAP3-42.00	TAK3-42.00	TAN3-42.00
3-C	42.07	1.6563	1-21/32	6.35	TAP3-42.07	TAK3-42.07	TAN3-42.07
3-C	42.10	1.6575		6.35	TAP3-42.10	TAK3-42.10	TAN3-42.10
3-C	42.20	1.6614		6.35	TAP3-42.20	TAK3-42.20	TAN3-42.20
3-C	42.30	1.6654		6.35	TAP3-42.30	TAK3-42.30	TAN3-42.30
3-C	42.40	1.6693		6.35	TAP3-42.40	TAK3-42.40	TAN3-42.40
3-C	42.50	1.6732		6.35	TAP3-42.50	TAK3-42.50	TAN3-42.50
3-C	42.60	1.6772		6.35	TAP3-42.60	TAK3-42.60	TAN3-42.60
3-C	42.70	1.6811		6.35	TAP3-42.70	TAK3-42.70	TAN3-42.70
3-C	42.80	1.6850		6.35	TAP3-42.80	TAK3-42.80	TAN3-42.80
3-C	42.86	1.6874	1-11/16	6.35	TAP3-42.86	TAK3-42.86	TAN3-42.86
3-C	42.90	1.6890		6.35	TAP3-42.90	TAK3-42.90	TAN3-42.90
3-C	43.00	1.6929		6.35	TAP3-43.00	TAK3-43.00	TAN3-43.00
3-C	43.10	1.6969		6.35	TAP3-43.10	TAK3-43.10	TAN3-43.10
3-C	43.20	1.7008		6.35	TAP3-43.20	TAK3-43.20	TAN3-43.20
3-C	43.30	1.7047		6.35	TAP3-43.30	TAK3-43.30	TAN3-43.30
3-C	43.40	1.7087		6.35	TAP3-43.40	TAK3-43.40	TAN3-43.40
3-C	43.50	1.7126		6.35	TAP3-43.50	TAK3-43.50	TAN3-43.50
3-C	43.60	1.7165		6.35	TAP3-43.60	TAK3-43.60	TAN3-43.60
3-C	43.66	1.7189	1-23/32	6.35	TAP3-43.66	TAK3-43.66	TAN3-43.66
3-C	43.70	1.7205		6.35	TAP3-43.70	TAK3-43.70	TAN3-43.70
3-C	43.80	1.7244		6.35	TAP3-43.80	TAK3-43.80	TAN3-43.80
3-C	43.90	1.7283		6.35	TAP3-43.90	TAK3-43.90	TAN3-43.90
3-C	44.00	1.7323		6.35	TAP3-44.00	TAK3-44.00	TAN3-44.00
3-C	44.10	1.7362		6.35	TAP3-44.10	TAK3-44.10	TAN3-44.10
3-C	44.20	1.7402		6.35	TAP3-44.20	TAK3-44.20	TAN3-44.20
3-C	44.30	1.7441		6.35	TAP3-44.30	TAK3-44.30	TAN3-44.30

Inserts sold in multiples of 1

Sub Series Holders (A, B, C, D)
 Sub series holders are recommended when running carbide inserts toward the upper end of the series drill range, as well as in tougher applications requiring more insert support and holder strength. NOTE: Only specified sub series inserts should be used with equivalent or smaller sub series holders.

A Series Insert + A Series Holder

C Series Insert + A Series Holder

C Series Insert + C Series Holder

A Series Insert + C Series Holder

A25: 50 - 53
 A25: 48 - 49

Sizes not shown are available upon request.
 When ordering, please follow the example below:

Metric:	13.16mm, Steel, 0 series = use Part No. TAP0-13.16
Imperial:	0.5180", Steel, 0 series = use Part No. TAP0-13.16

T-A Pro Carbide Drill Inserts

3 Series | Diameter Range: 35.05mm - 47.80mm

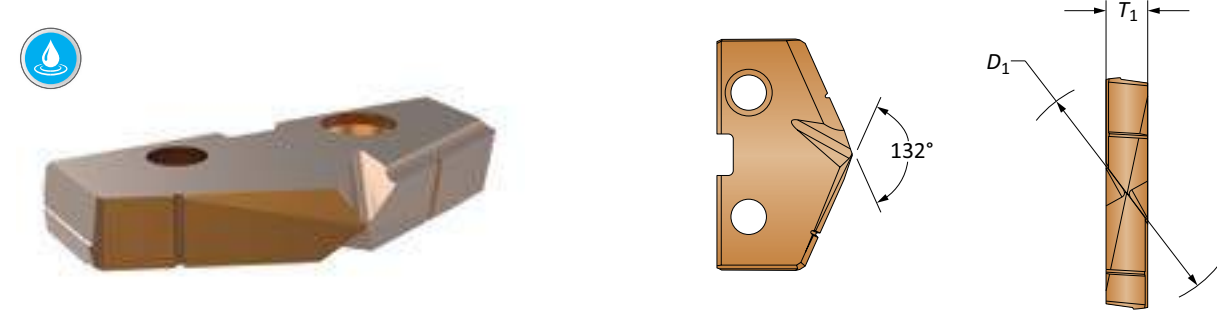

Series	Insert				Part No. P	Part No. K	Part No. N
	D ₁ mm	D ₁ inch	Fractional Equivalent	T ₁ mm			
3-D	44.40	1.7480		6.35	TAP3-44.40	TAK3-44.40	TAN3-44.40
3-D	44.45	1.7500	1-3/4	6.35	TAP3-44.45	TAK3-44.45	TAN3-44.45
3-D	44.50	1.7520		6.35	TAP3-44.50	TAK3-44.50	TAN3-44.50
3-D	44.60	1.7559		6.35	TAP3-44.60	TAK3-44.60	TAN3-44.60
3-D	44.70	1.7598		6.35	TAP3-44.70	TAK3-44.70	TAN3-44.70
3-D	44.80	1.7638		6.35	TAP3-44.80	TAK3-44.80	TAN3-44.80
3-D	44.90	1.7677		6.35	TAP3-44.90	TAK3-44.90	TAN3-44.90
3-D	45.00	1.7717		6.35	TAP3-45.00	TAK3-45.00	TAN3-45.00
3-D	45.10	1.7756		6.35	TAP3-45.10	TAK3-45.10	TAN3-45.10
3-D	45.20	1.7795		6.35	TAP3-45.20	TAK3-45.20	TAN3-45.20
3-D	45.24	1.7811	1-25/32	6.35	TAP3-45.24	TAK3-45.24	TAN3-45.24
3-D	45.30	1.7835		6.35	TAP3-45.30	TAK3-45.30	TAN3-45.30
3-D	45.40	1.7874		6.35	TAP3-45.40	TAK3-45.40	TAN3-45.40
3-D	45.50	1.7913		6.35	TAP3-45.50	TAK3-45.50	TAN3-45.50
3-D	45.50	1.7913		6.35	TAP3-45.50	TAK3-45.50	TAN3-45.50
3-D	45.60	1.7953		6.35	TAP3-45.60	TAK3-45.60	TAN3-45.60
3-D	45.64	1.7969		6.35	TAP3-45.64	TAK3-45.64	TAN3-45.64
3-D	45.70	1.7992		6.35	TAP3-45.70	TAK3-45.70	TAN3-45.70
3-D	45.80	1.8031		6.35	TAP3-45.80	TAK3-45.80	TAN3-45.80
3-D	45.90	1.8071		6.35	TAP3-45.90	TAK3-45.90	TAN3-45.90
3-D	46.00	1.8110		6.35	TAP3-46.00	TAK3-46.00	TAN3-46.00
3-D	46.04	1.8126	1-13/16	6.35	TAP3-46.04	TAK3-46.04	TAN3-46.04
3-D	46.10	1.8150		6.35	TAP3-46.10	TAK3-46.10	TAN3-46.10
3-D	46.20	1.8189		6.35	TAP3-46.20	TAK3-46.20	TAN3-46.20
3-D	46.30	1.8228		6.35	TAP3-46.30	TAK3-46.30	TAN3-46.30
3-D	46.40	1.8268		6.35	TAP3-46.40	TAK3-46.40	TAN3-46.40
3-D	46.50	1.8307		6.35	TAP3-46.50	TAK3-46.50	TAN3-46.50
3-D	46.60	1.8346		6.35	TAP3-46.60	TAK3-46.60	TAN3-46.60
3-D	46.70	1.8386		6.35	TAP3-46.70	TAK3-46.70	TAN3-46.70
3-D	46.80	1.8425		6.35	TAP3-46.80	TAK3-46.80	TAN3-46.80
3-D	46.83	1.8437	1-27/32	6.35	TAP3-46.83	TAK3-46.83	TAN3-46.83
3-D	46.90	1.8465		6.35	TAP3-46.90	TAK3-46.90	TAN3-46.90
3-D	47.00	1.8504		6.35	TAP3-47.00	TAK3-47.00	TAN3-47.00
3-D	47.10	1.8543		6.35	TAP3-47.10	TAK3-47.10	TAN3-47.10
3-D	47.20	1.8583		6.35	TAP3-47.20	TAK3-47.20	TAN3-47.20
3-D	47.30	1.8622		6.35	TAP3-47.30	TAK3-47.30	TAN3-47.30
3-D	47.40	1.8661		6.35	TAP3-47.40	TAK3-47.40	TAN3-47.40
3-D	47.50	1.8661		6.35	TAP3-47.50	TAK3-47.50	TAN3-47.50
3-D	47.60	1.8740		6.35	TAP3-47.60	TAK3-47.60	TAN3-47.60
3-D	47.63	1.8752	1-7/8	6.35	TAP3-47.63	TAK3-47.63	TAN3-47.63

Inserts sold in multiples of 1

Sub Series Holders (A, B, C, D)
 Sub series holders are recommended when running carbide inserts toward the upper end of the series drill range, as well as in tougher applications requiring more insert support and holder strength. NOTE: Only specified sub series inserts should be used with equivalent or smaller sub series holders.

A Series Insert + A Series Holder

C Series Insert + A Series Holder

C Series Insert + C Series Holder

A Series Insert + C Series Holder

A25: 50 - 53
 A25: 48 - 49

Sizes not shown are available upon request.
 When ordering, please follow the example below:

Metric:	13.16mm, Steel, 0 series = use Part No. TAP0-13.16
Imperial:	0.5180", Steel, 0 series = use Part No. TAP0-13.16

T-A Pro HSS Drill Inserts

3 Series | Diameter Range: 35.05mm - 47.80mm

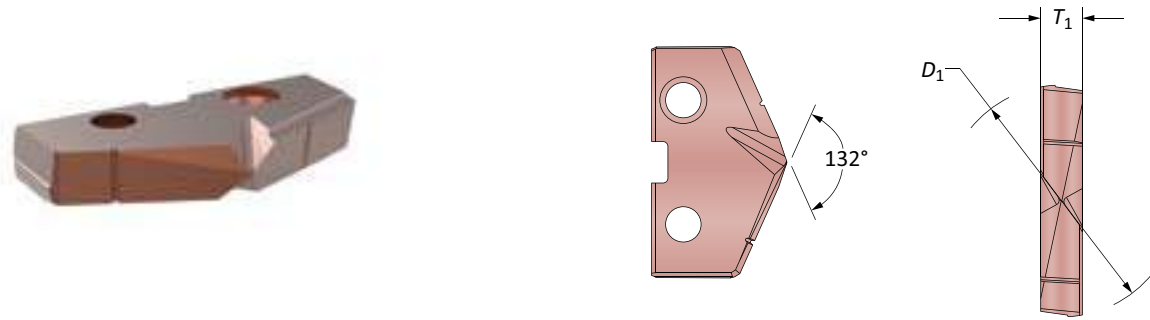

Series	D ₁ mm	D ₁ inch	Fractional Equivalent	T ₁ mm	Insert
					Part No.
					X
3-A	35.72	1.4063	1-13/32	6.35	TAX3-35.72
3-A	35.80	1.4094		6.35	TAX3-35.80
3-A	35.90	1.4134		6.35	TAX3-35.90
3-A	36.00	1.4173		6.35	TAX3-36.00
3-A	36.10	1.4213		6.35	TAX3-36.10
3-A	36.20	1.4252		6.35	TAX3-36.20
3-A	36.30	1.4291		6.35	TAX3-36.30
3-A	36.40	1.4331		6.35	TAX3-36.40
3-A	36.50	1.4370		6.35	TAX3-36.50
3-A	36.51	1.4374	1-7/16	6.35	TAX3-36.51
3-A	36.60	1.4409		6.35	TAX3-36.60
3-A	36.70	1.4449		6.35	TAX3-36.70
3-A	36.80	1.4488		6.35	TAX3-36.80
3-A	36.90	1.4528		6.35	TAX3-36.90
3-A	37.00	1.4567		6.35	TAX3-37.00
3-A	37.10	1.4606		6.35	TAX3-37.10
3-A	37.20	1.4646		6.35	TAX3-37.20
3-A	37.30	1.4685		6.35	TAX3-37.30
3-A	37.31	1.4689	1-15/32	6.35	TAX3-37.31
3-A	37.40	1.4724		6.35	TAX3-37.40
3-A	37.50	1.4764		6.35	TAX3-37.50
3-A	37.60	1.4803		6.35	TAX3-37.60
3-A	37.70	1.4843		6.35	TAX3-37.70

Inserts sold in multiples of 1

T-A Pro HSS Drill Inserts

3 Series | Diameter Range: 35.05mm - 47.80mm

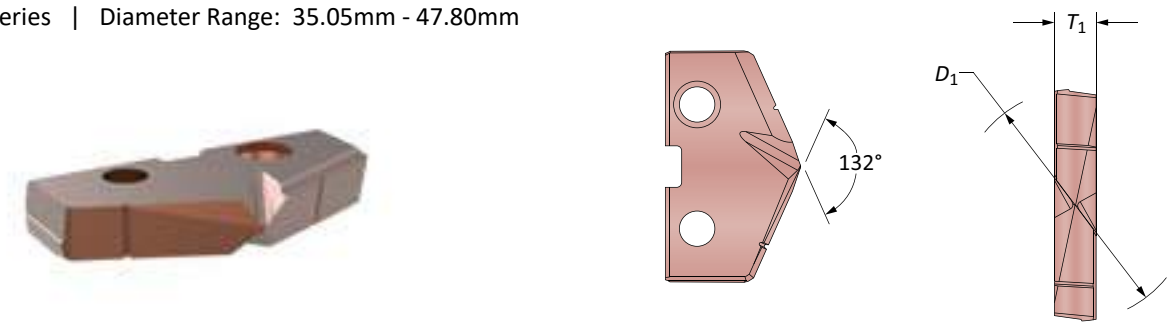

Series	D ₁ mm	D ₁ inch	Fractional Equivalent	T ₁ mm	Insert
					Part No.
					X
3-B	37.80	1.4882		6.35	TAX3-37.80
3-B	37.90	1.4921		6.35	TAX3-37.90
3-B	38.00	1.4961		6.35	TAX3-38.00
3-B	38.10	1.5000	1-1/2	6.35	TAX3-38.10
3-B	38.20	1.5039		6.35	TAX3-38.20
3-B	38.30	1.5079		6.35	TAX3-38.30
3-B	38.40	1.5118		6.35	TAX3-38.40
3-B	38.50	1.5157		6.35	TAX3-38.50
3-B	38.60	1.5197		6.35	TAX3-38.60
3-B	38.70	1.5236		6.35	TAX3-38.70
3-B	38.80	1.5276		6.35	TAX3-38.80
3-B	38.89	1.5311	1-17/32	6.35	TAX3-38.89
3-B	38.90	1.5315		6.35	TAX3-38.90
3-B	39.00	1.5354		6.35	TAX3-39.00
3-B	39.10	1.5394		6.35	TAX3-39.10
3-B	39.20	1.5433		6.35	TAX3-39.20
3-B	39.29	1.5469		6.35	TAX3-39.29
3-B	39.30	1.5472		6.35	TAX3-39.30
3-B	39.40	1.5512		6.35	TAX3-39.40
3-B	39.50	1.5551		6.35	TAX3-39.50
3-B	39.60	1.5591		6.35	TAX3-39.60
3-B	39.69	1.5626	1-9/16	6.35	TAX3-39.69
3-B	39.70	1.5630		6.35	TAX3-39.70
3-B	39.80	1.5669		6.35	TAX3-39.80
3-B	39.90	1.5709		6.35	TAX3-39.90
3-B	40.00	1.5748		6.35	TAX3-40.00
3-B	40.10	1.5787		6.35	TAX3-40.10
3-B	40.20	1.5827		6.35	TAX3-40.20
3-B	40.30	1.5866		6.35	TAX3-40.30
3-B	40.40	1.5906		6.35	TAX3-40.40
3-B	40.48	1.5937	1-19/32	6.35	TAX3-40.48
3-B	40.50	1.5945		6.35	TAX3-40.50
3-B	40.60	1.5984		6.35	TAX3-40.60
3-B	40.70	1.6024		6.35	TAX3-40.70
3-B	40.80	1.6063		6.35	TAX3-40.80
3-B	40.90	1.6102		6.35	TAX3-40.90

Inserts sold in multiples of 1

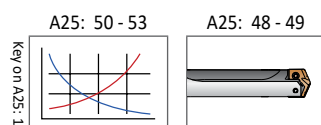

Sizes not shown are available upon request.
When ordering, please follow the example below:
Metric: 13.16mm, Steel, 0 series = use Part No. **TAP0-13.16**
Imperial: 0.5180", Steel, 0 series = use Part No. **TAP0-13.16**

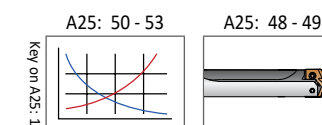

Sizes not shown are available upon request.
When ordering, please follow the example below:
Metric: 13.16mm, Steel, 0 series = use Part No. **TAP0-13.16**
Imperial: 0.5180", Steel, 0 series = use Part No. **TAP0-13.16**

T-A Pro HSS Drill Inserts

3 Series | Diameter Range: 35.05mm - 47.80mm

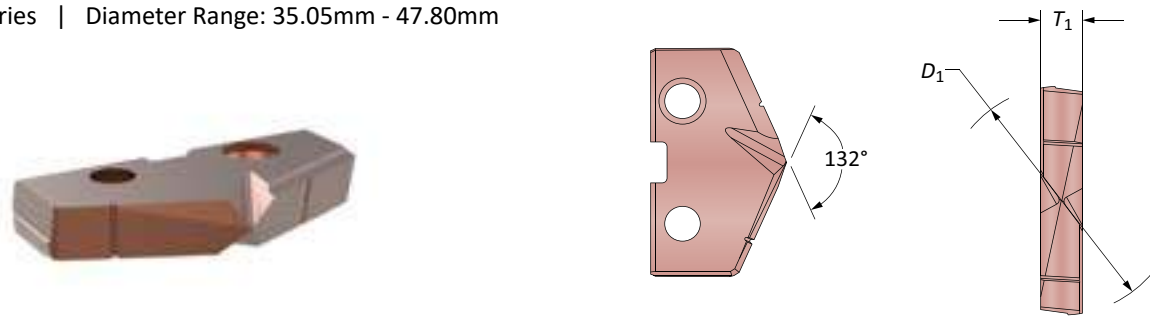

Series	Insert				Part No. X
	D ₁ mm	D ₁ inch	Fractional Equivalent	T ₁ mm	
3-C	41.00	1.6142		6.35	TAX3-41.00
3-C	41.10	1.6181		6.35	TAX3-41.10
3-C	41.20	1.6220		6.35	TAX3-41.20
3-C	41.28	1.6252	1-5/8	6.35	TAX3-41.28
3-C	41.30	1.6260		6.35	TAX3-41.30
3-C	41.40	1.6299		6.35	TAX3-41.40
3-C	41.50	1.6339		6.35	TAX3-41.50
3-C	41.60	1.6378		6.35	TAX3-41.60
3-C	41.70	1.6417		6.35	TAX3-41.70
3-C	41.80	1.6457		6.35	TAX3-41.80
3-C	41.90	1.6496		6.35	TAX3-41.90
3-C	42.00	1.6535		6.35	TAX3-42.00
3-C	42.07	1.6563	1-21/32	6.35	TAX3-42.07
3-C	42.10	1.6575		6.35	TAX3-42.10
3-C	42.20	1.6614		6.35	TAX3-42.20
3-C	42.30	1.6654		6.35	TAX3-42.30
3-C	42.40	1.6693		6.35	TAX3-42.40
3-C	42.50	1.6732		6.35	TAX3-42.50
3-C	42.60	1.6772		6.35	TAX3-42.60
3-C	42.70	1.6811		6.35	TAX3-42.70
3-C	42.80	1.6850		6.35	TAX3-42.80
3-C	42.86	1.6874	1-11/16	6.35	TAX3-42.86
3-C	42.90	1.6890		6.35	TAX3-42.90
3-C	43.00	1.6929		6.35	TAX3-43.00
3-C	43.10	1.6969		6.35	TAX3-43.10
3-C	43.20	1.7008		6.35	TAX3-43.20
3-C	43.30	1.7047		6.35	TAX3-43.30
3-C	43.40	1.7087		6.35	TAX3-43.40
3-C	43.50	1.7126		6.35	TAX3-43.50
3-C	43.60	1.7165		6.35	TAX3-43.60
3-C	43.66	1.7189	1-23/32	6.35	TAX3-43.66
3-C	43.70	1.7205		6.35	TAX3-43.70
3-C	43.80	1.7244		6.35	TAX3-43.80
3-C	43.90	1.7283		6.35	TAX3-43.90
3-C	44.00	1.7323		6.35	TAX3-44.00
3-C	44.10	1.7362		6.35	TAX3-44.10
3-C	44.20	1.7402		6.35	TAX3-44.20
3-C	44.30	1.7441		6.35	TAX3-44.30

Inserts sold in multiples of 1

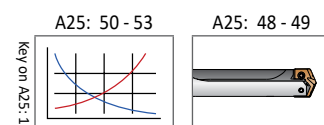

Sizes not shown are available upon request.
When ordering, please follow the example below:
Metric: 13.16mm, Steel, 0 series = use Part No. **TAP0-13.16**
Imperial: 0.5180", Steel, 0 series = use Part No. **TAP0-13.16**

T-A Pro HSS Drill Inserts

3 Series | Diameter Range: 35.05mm - 47.80mm

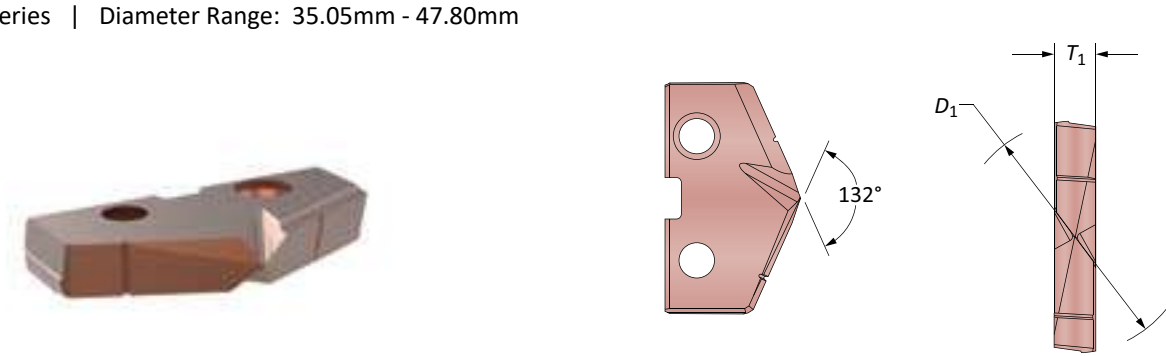

Series	Insert				Part No. X
	D ₁ mm	D ₁ inch	Fractional Equivalent	T ₁ mm	
3-D	44.40	1.7480		6.35	TAX3-44.40
3-D	44.45	1.7500	1-3/4	6.35	TAX3-44.45
3-D	44.50	1.7520		6.35	TAX3-44.50
3-D	44.60	1.7559		6.35	TAX3-44.60
3-D	44.70	1.7598		6.35	TAX3-44.70
3-D	44.80	1.7638		6.35	TAX3-44.80
3-D	44.90	1.7677		6.35	TAX3-44.90
3-D	45.00	1.7717		6.35	TAX3-45.00
3-D	45.10	1.7756		6.35	TAX3-45.10
3-D	45.20	1.7795		6.35	TAX3-45.20
3-D	45.24	1.7811	1-25/32	6.35	TAX3-45.24
3-D	45.30	1.7835		6.35	TAX3-45.30
3-D	45.40	1.7874		6.35	TAX3-45.40
3-D	45.50	1.7913		6.35	TAX3-45.50
3-D	45.60	1.7953		6.35	TAX3-45.60
3-D	45.64	1.7969		6.35	TAX3-45.64
3-D	45.70	1.7992		6.35	TAX3-45.70
3-D	45.80	1.8031		6.35	TAX3-45.80
3-D	45.90	1.8071		6.35	TAX3-45.90
3-D	46.00	1.8110		6.35	TAX3-46.00
3-D	46.04	1.8126	1-13/16	6.35	TAX3-46.04
3-D	46.10	1.8150		6.35	TAX3-46.10
3-D	46.20	1.8189		6.35	TAX3-46.20
3-D	46.30	1.8228		6.35	TAX3-46.30
3-D	46.40	1.8268		6.35	TAX3-46.40
3-D	46.50	1.8307		6.35	TAX3-46.50
3-D	46.60	1.8346		6.35	TAX3-46.60
3-D	46.70	1.8386		6.35	TAX3-46.70
3-D	46.80	1.8425		6.35	TAX3-46.80
3-D	46.83	1.8437	1-27/32	6.35	TAX3-46.83
3-D	46.90	1.8465		6.35	TAX3-46.90
3-D	47.00	1.8504		6.35	TAX3-47.00
3-D	47.10	1.8543		6.35	TAX3-47.10
3-D	47.20	1.8583		6.35	TAX3-47.20
3-D	47.30	1.8622		6.35	TAX3-47.30
3-D	47.40	1.8661		6.35	TAX3-47.40
3-D	47.50	1.8661		6.35	TAX3-47.50
3-D	47.60	1.8740		6.35	TAX3-47.60
3-D	47.63	1.8752	1-7/8	6.35	TAX3-47.63

Inserts sold in multiples of 1

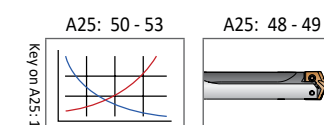

Sizes not shown are available upon request.
When ordering, please follow the example below:
Metric: 13.16mm, Steel, 0 series = use Part No. **TAP0-13.16**
Imperial: 0.5180", Steel, 0 series = use Part No. **TAP0-13.16**

T-A Pro Drill Holders

3 Series Metric | Diameter Range: 35.05mm - 47.80mm

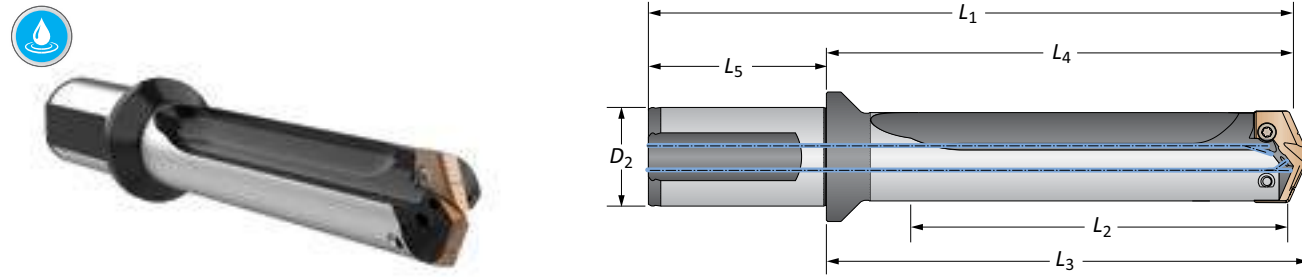

Length	Sub Series	Series Diameter	Body				Shank			Part No
			L ₂ mm	L ₄ mm	L ₃ mm	L ₁ mm	L ₅ mm	D ₂ mm	Flat	
STUB	A	35.72 - 37.70	41.1	92.3	97.1	160.6	68.3	40	Yes	HTA3A01-40FM
STUB	A	35.72 - 37.70	41.1	92.3	97.1	160.6	68.3	40	No	HTA3A01-40CM
STUB	B	37.80 - 40.90	41.1	92.3	97.1	160.6	68.3	40	Yes	HTA3B01-40FM
STUB	B	37.80 - 40.90	41.1	92.3	97.1	160.6	68.3	40	No	HTA3B01-40CM
STUB	C	41.00 - 44.30	41.1	92.3	97.1	160.6	68.3	40	Yes	HTA3C01-40FM
STUB	C	41.00 - 44.30	41.1	92.3	97.1	160.6	68.3	40	No	HTA3C01-40CM
STUB	D	44.40 - 47.63	41.1	92.3	97.1	160.6	68.3	40	Yes	HTA3D01-40FM
STUB	D	44.40 - 47.63	41.1	92.3	97.1	160.6	68.3	40	No	HTA3D01-40CM
3xD	A	35.72 - 37.70	123.3	180.1	184.8	248.3	68.3	40	Yes	HTA3A03-40FM
3xD	A	35.72 - 37.70	123.3	180.1	184.8	248.3	68.3	40	No	HTA3A03-40CM
3xD	B	37.80 - 40.90	123.3	180.1	184.8	248.3	68.3	40	Yes	HTA3B03-40FM
3xD	B	37.80 - 40.90	123.3	180.1	184.8	248.3	68.3	40	No	HTA3B03-40CM
3xD	C	41.00 - 44.30	123.3	180.1	184.8	248.3	68.3	40	Yes	HTA3C03-40FM
3xD	C	41.00 - 44.30	123.3	180.1	184.8	248.3	68.3	40	No	HTA3C03-40CM
3xD	D	44.40 - 47.63	123.3	180.1	184.8	248.3	68.3	40	Yes	HTA3D03-40FM
3xD	D	44.40 - 47.63	123.3	180.1	184.8	248.3	68.3	40	No	HTA3D03-40CM
5xD	A	35.72 - 37.70	205.5	262.2	267.0	330.5	68.3	40	Yes	HTA3A05-40FM
5xD	A	35.72 - 37.70	205.5	262.2	267.0	330.5	68.3	40	No	HTA3A05-40CM
5xD	B	37.80 - 40.90	205.5	262.2	267.0	330.5	68.3	40	Yes	HTA3B05-40FM
5xD	B	37.80 - 40.90	205.5	262.2	267.0	330.5	68.3	40	No	HTA3B05-40CM
5xD	C	41.00 - 44.30	205.5	262.2	267.0	330.5	68.3	40	Yes	HTA3C05-40FM
5xD	C	41.00 - 44.30	205.5	262.2	267.0	330.5	68.3	40	No	HTA3C05-40CM
5xD	D	44.40 - 47.63	205.5	262.2	267.0	330.5	68.3	40	Yes	HTA3D05-40FM
5xD	D	44.40 - 47.63	205.5	262.2	267.0	330.5	68.3	40	No	HTA3D05-40CM
7xD	A	35.72 - 37.70	287.7	344.4	349.2	412.7	68.3	40	Yes	HTA3A07-40FM
7xD	A	35.72 - 37.70	287.7	344.4	349.2	412.7	68.3	40	No	HTA3A07-40CM
7xD	B	37.80 - 40.90	287.7	344.4	349.2	412.7	68.3	40	Yes	HTA3B07-40FM
7xD	B	37.80 - 40.90	287.7	344.4	349.2	412.7	68.3	40	No	HTA3B07-40CM
7xD	C	41.00 - 44.30	287.7	344.4	349.2	412.7	68.3	40	Yes	HTA3C07-40FM
7xD	C	41.00 - 44.30	287.7	344.4	349.2	412.7	68.3	40	No	HTA3C07-40CM
7xD	D	44.40 - 47.63	287.7	344.4	349.2	412.7	68.3	40	Yes	HTA3D07-40FM
7xD	D	44.40 - 47.63	287.7	344.4	349.2	412.7	68.3	40	No	HTA3D07-40CM

Connection Accessories

			Admissible Tightening Torque*
7514-IP20-1	7514N-IP20-1	8IP-20	1370 N-cm (121.3 in-lbs)

WARNING Refer to Speed and Feed charts for recommended adjustments to speeds and feeds. Refer to page A25: 54 for deep hole drilling guidelines in this section of the catalog. Visit www.alliedmachine.com/DeepHoleGuidelines for the most up-to-date information and procedures. Factory technical assistance is available for your specific applications through our Application Engineering department. Email: engineering.eu@alliedmachine.com



Ⓜ = Metric (mm)
 Ⓡ = Imperial (in)
 Screws sold in multiples of 10

T-A Pro Drill Holders

3 Series Metric | Diameter Range: 35.05mm - 47.80mm

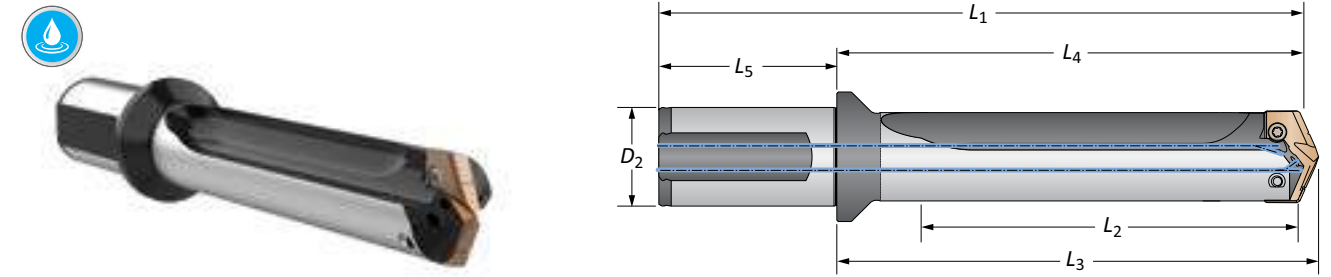

Length	Sub Series	Series Diameter	Body				Shank			Part No
			L ₂ mm	L ₄ mm	L ₃ mm	L ₁ mm	L ₅ mm	D ₂ mm	Flat	
10xD	A	35.72 - 37.70	411.0	467.7	472.5	536.0	68.3	40	Yes	HTA3A10-40FM
10xD	A	35.72 - 37.70	411.0	467.7	472.5	536.0	68.3	40	No	HTA3A10-40CM
10xD	B	37.80 - 40.90	411.0	467.7	472.5	536.0	68.3	40	Yes	HTA3B10-40FM
10xD	B	37.80 - 40.90	411.0	467.7	472.5	536.0	68.3	40	No	HTA3B10-40CM
10xD	C	41.00 - 44.30	411.0	467.7	472.5	536.0	68.3	40	Yes	HTA3C10-40FM
10xD	C	41.00 - 44.30	411.0	467.7	472.5	536.0	68.3	40	No	HTA3C10-40CM
10xD	D	44.40 - 47.63	411.0	467.7	472.5	536.0	68.3	40	Yes	HTA3D10-40FM
10xD	D	44.40 - 47.63	411.0	467.7	472.5	536.0	68.3	40	No	HTA3D10-40CM
12xD	A	35.72 - 37.70	493.2	549.9	554.7	618.2	68.3	40	Yes	HTA3A12-40FM
12xD	A	35.72 - 37.70	493.2	549.9	554.7	618.2	68.3	40	No	HTA3A12-40CM
12xD	B	37.80 - 40.90	493.2	549.9	554.7	618.2	68.3	40	Yes	HTA3B12-40FM
12xD	B	37.80 - 40.90	493.2	549.9	554.7	618.2	68.3	40	No	HTA3B12-40CM
12xD	C	41.00 - 44.30	493.2	549.9	554.7	618.2	68.3	40	Yes	HTA3C12-40FM
12xD	C	41.00 - 44.30	493.2	549.9	554.7	618.2	68.3	40	No	HTA3C12-40CM
12xD	D	44.40 - 47.63	493.2	549.9	554.7	618.2	68.3	40	Yes	HTA3D12-40FM
12xD	D	44.40 - 47.63	493.2	549.9	554.7	618.2	68.3	40	No	HTA3D12-40CM
15xD	A	35.72 - 37.70	616.5	673.2	678.0	741.5	68.3	40	Yes	HTA3A15-40FM
15xD	A	35.72 - 37.70	616.5	673.2	678.0	741.5	68.3	40	No	HTA3A15-40CM
15xD	B	37.80 - 40.90	616.5	673.2	678.0	741.5	68.3	40	Yes	HTA3B15-40FM
15xD	B	37.80 - 40.90	616.5	673.2	678.0	741.5	68.3	40	No	HTA3B15-40CM
15xD	C	41.00 - 44.30	616.5	673.2	678.0	741.5	68.3	40	Yes	HTA3C15-40FM
15xD	C	41.00 - 44.30	616.5	673.2	678.0	741.5	68.3	40	No	HTA3C15-40CM
15xD	D	44.40 - 47.63	616.5	673.2	678.0	741.5	68.3	40	Yes	HTA3D15-40FM
15xD	D	44.40 - 47.63	616.5	673.2	678.0	741.5	68.3	40	No	HTA3D15-40CM

Connection Accessories

			Admissible Tightening Torque*
7514-IP20-1	7514N-IP20-1	8IP-20	1370 N-cm (121.3 in-lbs)

WARNING Refer to Speed and Feed charts for recommended adjustments to speeds and feeds. Refer to page A25: 54 for deep hole drilling guidelines in this section of the catalog. Visit www.alliedmachine.com/DeepHoleGuidelines for the most up-to-date information and procedures. Factory technical assistance is available for your specific applications through our Application Engineering department. Email: engineering.eu@alliedmachine.com



Ⓜ = Metric (mm)
 Ⓡ = Imperial (in)
 Screws sold in multiples of 10

T-A Pro™ Recommended Drilling Data | Metric (mm)

Carbide

Material	Hardness (BHN)	Insert Grade	Speed (M/min)	Feed Rate (mm/rev) by Diameter				
				11.10mm - 12.69mm	12.70mm - 17.64mm	17.65mm - 24.37mm	24.38mm - 35.04mm	35.05mm - 47.80mm
Free Machining Steel 1111Mn30, 10S20, 11SMn36, etc.	100 - 150	P	145	0.18	0.25	0.33	0.41	0.51
	150 - 200	P	135	0.18	0.25	0.33	0.41	0.51
	200 - 250	P	125	0.15	0.25	0.33	0.41	0.51
Low Carbon Steel C22, C10, CK22, 15Cr3, etc.	85 - 125	P	130	0.15	0.23	0.30	0.38	0.48
	125 - 175	P	125	0.15	0.23	0.30	0.38	0.48
	175 - 225	P	115	0.13	0.20	0.25	0.36	0.46
	225 - 275	P	110	0.13	0.20	0.25	0.36	0.46
Medium Carbon Steel C45, C60, 30Mn5, etc.	125 - 175	P	125	0.15	0.23	0.30	0.38	0.48
	175 - 225	P	115	0.13	0.20	0.25	0.36	0.46
	225 - 275	P	110	0.13	0.20	0.25	0.36	0.46
Alloy Steel 42CrM04, 36NiCr10, 10NiCrMo13 4, etc.	125 - 175	P	130	0.15	0.23	0.30	0.36	0.43
	175 - 225	P	120	0.13	0.20	0.28	0.36	0.43
	225 - 275	P	110	0.13	0.20	0.28	0.36	0.43
	275 - 325	P	105	0.10	0.18	0.25	0.30	0.38
	325 - 375	P	95	0.08	0.18	0.25	0.30	0.38
High Strength Alloy 34NiCrMo8, etc.	225 - 300	P	105	0.10	0.18	0.25	0.33	0.38
	300 - 350	P	100	0.08	0.15	0.23	0.30	0.36
	350 - 400	P	90	0.08	0.15	0.20	0.28	0.33
	400 - 450	P	85	0.08	0.15	0.20	0.28	0.33
Structural Steel 1St37, St52, S355, etc.	100 - 150	P	120	0.15	0.25	0.30	0.36	0.46
	150 - 250	P	105	0.13	0.23	0.25	0.30	0.41
	250 - 350	P	85	0.10	0.20	0.23	0.25	0.36
Tool Steel 1.2714, 1.2379, 1.2344 etc.	150 - 200	P	65	0.10	0.15	0.20	0.25	0.30
	200 - 250	P	55	0.10	0.15	0.20	0.25	0.30
High Temp Alloy Hastelloy B, Inconel 600, etc.	140 - 220	M	20	0.08	0.18	0.20	0.25	0.30
	220 - 310	M	15	0.08	0.15	0.18	0.20	0.25
	140 - 220	M	20	0.08	0.18	0.20	0.25	0.30
	220 - 310	M	15	0.08	0.15	0.18	0.20	0.25
	185 - 275	M	45	0.13	0.20	0.23	0.25	0.36
Titanium Alloy S82	185 - 275	M	45	0.13	0.20	0.23	0.25	0.36
	275 - 350	M	35	0.10	0.18	0.20	0.2	0.30

7xD and 10xD Adjustment Example (0.80 Adjustment)

Data • Adjustment Value	Speed/Feed (7xD)
100 M/min • 0.80	= 80 M/min
0.2 mm/rev • 0.80	= 0.16 mm/rev

12xD and 15xD Adjustment Example (0.70 Adjustment)

Speed • Adjustment Value	Speed/Feed (10xD)
100 M/min • 0.70	= 70 M/min
0.2 mm/rev • 0.70	= 0.14 mm/rev

Coolant Recommendations

Series	STUB, 3xD, 5xD		7xD, 10xD		12xD, 15xD	
	Pressure BAR	Flow Rate LPM	Pressure BAR	Flow Rate LPM	Pressure BAR	Flow Rate LPM
Z	31	15	34	22	45	30
0	24	22	31	34	34	45
1	21	30	27	38	34	45
2	17	38	24	49	31	60
3	14	45	21	53	27	68

WARNING Tool failure can cause serious injury. To prevent:

- When using holders without support bushing, use a short T-A Pro holder to establish an initial hole that is a minimum of 2 diameters deep.
 - Do not rotate tool holders more than 50 RPM unless it is engaged with the workpiece or fixture.
- Visit www.alliedmachine.com/DeepHoleGuidelines for the most up-to-date information and procedures.
Factory technical assistance is available for your specific applications through our Application Engineering department. Email: engineering.eu@alliedmachine.com

IMPORTANT: The speeds and feeds listed above are a general starting point for all applications. Refer to the coolant recommendation chart for coolant requirements to run at the recommended speeds and feeds. Factory technical assistance is available through our Application Engineering department. For 7xD, 10xD, 12xD, and 15xD holder lengths, see adjustment example above.

T-A Pro™ Recommended Drilling Data | Metric (mm)

Carbide

Material	Hardness (BHN)	Insert Grade	Speed (M/min)	Feed Rate (mm/rev) by Diameter					
				11.10mm - 12.69mm	12.70mm - 17.64mm	17.65mm - 24.37mm	24.38mm - 35.04mm	35.05mm - 47.80mm	
M	Stainless Steel 400 Series 1.4404 etc.	185 - 275	M	85	0.13	0.25	0.28	0.30	0.33
		275 - 350	M	70	0.10	0.23	0.25	0.28	0.30
	Stainless Steel 300 Series 1.4571 etc.	135 - 185	M	85	0.13	0.18	0.20	0.23	0.30
		185 - 275	M	70	0.10	0.15	0.18	0.20	0.28
	PH Stainless 17-4, 13-8, 15-5	275-350	P	50	0.08	0.10	0.15	0.20	0.25
		350-425	P	35	0.08	0.10	0.15	0.20	0.25
Super Duplex Stainless Steel	135 - 185	M	35	0.13	0.13	0.15	0.15	0.18	
	185 - 275	M	25	0.10	0.13	0.13	0.15	0.15	
H	Wear Plate Hardox, AR400, T-1, etc.	400	P	20	0.08	0.15	0.20	0.23	0.30
		500	P	15	0.05	0.13	0.18	0.20	0.25
		600	N/A	-	-	-	-	-	-
K	Hardened Steel	300 - 400	P	30	0.08	0.15	0.20	0.23	0.30
		400 - 500	P	15	0.05	0.13	0.18	0.20	0.25
		120 - 150	K	185	0.18	0.30	0.41	0.51	0.61
N	SG / Nodular Cast Iron	150 - 200	K	170	0.15	0.28	0.36	0.46	0.56
		200 - 220	K	150	0.15	0.23	0.30	0.41	0.46
		220 - 260	K	135	0.13	0.18	0.23	0.30	0.36
		260 - 320	K	120	0.10	0.15	0.18	0.23	0.30
		30	N	335	0.20	0.33	0.41	0.51	0.56
N	Cast Aluminum	180	N	185	0.20	0.33	0.41	0.46	0.56
		30	N	335	0.23	0.33	0.43	0.51	0.61
	Wrought Aluminum	180	N	185	0.13	0.18	0.25	0.33	0.41
		100 - 200	N	150	0.15	0.28	0.36	0.46	0.56
	Aluminum Bronze	200 - 250	N	90	0.13	0.18	0.23	0.30	0.36
		100	N	135	0.18	0.30	0.41	0.51	0.61
Brass	60	N	50	0.05	0.08	0.15	0.20	0.25	
Copper									

7xD and 10xD Adjustment Example (0.80 Adjustment)

Data • Adjustment Value	Speed/Feed (7xD)
100 M/min • 0.80	= 80 M/min
0.2 mm/rev • 0.80	= 0.16 mm/rev

12xD and 15xD Adjustment Example (0.70 Adjustment)

Speed • Adjustment Value	Speed/Feed (10xD)
100 M/min • 0.70	= 70 M/min
0.2 mm/rev • 0.70	= 0.14 mm/rev

Coolant Recommendations

Series	STUB, 3xD, 5xD		7xD, 10xD		12xD, 15xD	
	Pressure BAR	Flow Rate LPM	Pressure BAR	Flow Rate LPM	Pressure BAR	Flow Rate LPM
Z	31	15	34	22	45	30
0	24	22	31	34	34	45
1	21	30	27	38	34	45
2	17	38	24	49	31	60
3	14	45	21	53	27	68

WARNING Tool failure can cause serious injury. To prevent:

- When using holders without support bushing, use a short T-A Pro holder to establish an initial hole that is a minimum of 2 diameters deep.
 - Do not rotate tool holders more than 50 RPM unless it is engaged with the workpiece or fixture.
- Visit www.alliedmachine.com/DeepHoleGuidelines for the most up-to-date information and procedures.
Factory technical assistance is available for your specific applications through our Application Engineering department. Email: engineering.eu@alliedmachine.com

IMPORTANT: The speeds and feeds listed above are a general starting point for all applications. Refer to the coolant recommendation chart for coolant requirements to run at the recommended speeds and feeds. Factory technical assistance is available through our Application Engineering department. For 7xD, 10xD, 12xD, and 15xD holder lengths, see adjustment example above.

T-A Pro™ Recommended Drilling Data | Metric (mm)

High-Speed Steel

Material	Hardness (BHN)	Insert Grade	Speed (M/min)	Feed Rate (mm/rev) by Diameter				
				9.50mm - 12.69mm	12.70mm - 17.51mm	17.52mm - 24.38mm	24.39mm - 35.00mm	35.01mm - 47.80mm
Free Machining Steel 1111Mn30, 10S20, 11SMn36, etc.	100 - 150	X	105	0.18	0.25	0.33	0.41	0.51
	150 - 200	X	100	0.18	0.25	0.33	0.41	0.51
	200 - 250	X	90	0.15	0.25	0.33	0.41	0.51
Low Carbon Steel C22, C10, CK22, 15Cr3, etc.	85 - 125	X	95	0.15	0.2	0.30	0.38	0.48
	125 - 175	X	90	0.15	0.23	0.30	0.38	0.48
	175 - 225	X	85	0.13	0.20	0.25	0.36	0.46
	225 - 275	X	80	0.13	0.20	0.25	0.36	0.46
Medium Carbon Steel C45, C60, 30Mn5, etc.	125 - 175	X	90	0.15	0.23	0.30	0.38	0.48
	175 - 225	X	85	0.13	0.20	0.25	0.36	0.46
	225 - 275	X	80	0.13	0.20	0.25	0.36	0.46
	275 - 325	X	70	0.10	0.18	0.23	0.30	0.41
Alloy Steel 42CrM04, 36NiCr10, 10NiCrMo13 4, etc.	125 - 175	X	75	0.15	0.23	0.30	0.36	0.43
	175 - 225	X	70	0.13	0.20	0.28	0.36	0.43
	225 - 275	X	65	0.13	0.20	0.28	0.36	0.43
	275 - 325	X	60	0.10	0.18	0.25	0.30	0.38
	325 - 375	X	60	0.08	0.18	0.25	0.30	0.38
High Strength Alloy 34NiCrMo8, etc.	225 - 300	X	40	0.10	0.18	0.25	0.33	0.38
	300 - 350	X	35	0.08	0.15	0.23	0.30	0.36
	350 - 400	X	25	0.08	0.15	0.20	0.28	0.33
	100 - 150	X	75	0.15	0.25	0.30	0.36	0.46
Structural Steel 1St37, St52, S355, etc.	150 - 250	X	65	0.13	0.23	0.25	0.30	0.41
	250 - 350	X	55	0.10	0.20	0.23	0.25	0.36
	150 - 200	X	45	0.10	0.15	0.20	0.25	0.30
Tool Steel 1.2714, 1.2379, 1.2344 etc.	200 - 250	X	35	0.10	0.15	0.20	0.25	0.30
	140 - 220	X	15	0.08	0.18	0.20	0.25	0.30
High Temp Alloy Hastelloy B, Inconel 600, etc.	220 - 310	X	10	0.08	0.15	0.18	0.20	0.25
	140 - 220	X	20	0.08	0.18	0.20	0.25	0.30
Titanium Alloy	220 - 310	X	15	0.08	0.15	0.18	0.20	0.25
	185 - 275	X	40	0.13	0.20	0.23	0.25	0.36
Aerospace Alloy S82	275 - 350	X	35	0.10	0.18	0.20	0.20	0.30

7xD and 10xD Adjustment Example (0.80 Adjustment)

Data • Adjustment Value	Speed/Feed (7xD)
100 M/min • 0.80	= 80 M/min
0.2 mm/rev • 0.80	= 0.16 mm/rev

12xD and 15xD Adjustment Example (0.70 Adjustment)

Speed • Adjustment Value	Speed/Feed (12xD)
100 M/min • 0.70	= 70 M/min
0.2 mm/rev • 0.70	= 0.14 mm/rev

Coolant Recommendations

Series	STUB, 3xD, 5xD		7xD, 10xD		12xD, 15xD	
	Pressure BAR	Flow Rate LPM	Pressure BAR	Flow Rate LPM	Pressure BAR	Flow Rate LPM
Z	31	15	34	22	45	30
0	24	22	31	34	34	45
1	21	30	27	38	34	45
2	17	38	24	49	31	60
3	14	45	21	53	27	68

⚠ WARNING Tool failure can cause serious injury. To prevent:

- When using holders without support bushing, use a short T-A Pro holder to establish an initial hole that is a minimum of 2 diameters deep.
- Do not rotate tool holders more than 50 RPM unless it is engaged with the workpiece or fixture.

Visit www.alliedmachine.com/DeepHoleGuidelines for the most up-to-date information and procedures.

Factory technical assistance is available for your specific applications through our Application Engineering department. Email: engineering.eu@alliedmachine.com

IMPORTANT: The speeds and feeds listed above are a general starting point for all applications. Refer to the coolant recommendation chart for coolant requirements to run at the recommended speeds and feeds. Factory technical assistance is available through our Application Engineering department. For 7xD, 10xD, 12xD, and 15xD holder lengths, see adjustment example above.

T-A Pro™ Recommended Drilling Data | Metric (mm)

High-Speed Steel

Material	Hardness (BHN)	Insert Grade	Speed (M/min)	Feed Rate (mm/rev) by Diameter					
				9.50mm - 12.69mm	12.70mm - 17.51mm	17.52mm - 24.38mm	24.39mm - 35.00mm	35.01mm - 47.80mm	
M	Stainless Steel 400 Series 1.4404 etc.	185 - 275	X	40	0.13	0.25	0.28	0.30	0.33
		275 - 350	X	35	0.10	0.23	0.25	0.28	0.30
	Stainless Steel 300 Series 1.4571 etc.	135 - 185	X	40	0.13	0.18	0.20	0.23	0.30
		185 - 275	X	35	0.10	0.15	0.18	0.20	0.28
	PH Stainless 17-4, 13-8, 15-5	275-350	X	30	0.08	0.10	0.15	0.20	0.25
350-425		X	25	0.08	0.10	0.15	0.20	0.25	
Super Duplex Stainless Steel	135 - 185	X	40	0.13	0.13	0.15	0.15	0.18	
	185 - 275	X	35	0.10	0.13	0.13	0.15	0.15	
H	Wear Plate Hardox, AR400, T-1, etc.	400	X	20	0.08	0.15	0.20	0.23	0.30
		500	X	15	0.05	0.13	0.18	0.20	0.25
		600	X	-	-	-	-	-	-
Hardened Steel	300 - 400	X	23	0.08	0.15	0.20	0.23	0.30	
	400 - 500	X	15	0.05	0.13	0.18	0.20	0.25	
K	SG / Nodular Cast Iron	120 - 150	X	90	0.18	0.30	0.41	0.51	0.61
		150 - 200	X	85	0.15	0.28	0.36	0.46	0.56
		200 - 220	X	75	0.15	0.23	0.30	0.41	0.46
		220 - 260	X	65	0.13	0.18	0.23	0.30	0.36
		260 - 320	X	55	0.10	0.15	0.18	0.23	0.30
N	Cast Aluminum	30	X	-	0.20	0.33	0.41	0.51	0.56
		180	X	-	0.20	0.33	0.41	0.46	0.56
	Wrought Aluminum	30	X	275	0.23	0.33	0.43	0.51	0.61
		180	X	185	0.13	0.18	0.25	0.33	0.41
	Aluminum Bronze	100 - 200	X	90	0.15	0.28	0.36	0.46	0.56
		200 - 250	X	75	0.13	0.18	0.23	0.30	0.36
	Brass	100	X	150	0.18	0.30	0.41	0.51	0.61
Copper	60	X	60	0.05	0.08	0.15	0.20	0.25	

7xD and 10xD Adjustment Example (0.80 Adjustment)

Data • Adjustment Value	Speed/Feed (7xD)
100 M/min • 0.80	= 80 M/min
0.2 mm/rev • 0.80	= 0.16 mm/rev

12xD and 15xD Adjustment Example (0.70 Adjustment)

Speed • Adjustment Value	Speed/Feed (12xD)
100 M/min • 0.70	= 70 M/min
0.2 mm/rev • 0.70	= 0.14 mm/rev

Coolant Recommendations

Series	STUB, 3xD, 5xD		7xD, 10xD		12xD, 15xD	
	Pressure BAR	Flow Rate LPM	Pressure BAR	Flow Rate LPM	Pressure BAR	Flow Rate LPM
Z	31	15	34	22	45	30
0	24	22	31	34	34	45
1	21	30	27	38	34	45
2	17	38	24	49	31	60
3	14	45	21	53	27	68

⚠ WARNING Tool failure can cause serious injury. To prevent:

- When using holders without support bushing, use a short T-A Pro holder to establish an initial hole that is a minimum of 2 diameters deep.
- Do not rotate tool holders more than 50 RPM unless it is engaged with the workpiece or fixture.







Visit www.alliedmachine.com/DeepHoleGuidelines for the most up-to-date information and procedures.

Factory technical assistance is available for your specific applications through our Application Engineering department. Email: engineering.eu@alliedmachine.com

IMPORTANT: The speeds and feeds listed above are a general starting point for all applications. Refer to the coolant recommendation chart for coolant requirements to run at the recommended speeds and feeds. Factory technical assistance is available through our Application Engineering department. For 7xD, 10xD, 12xD, and 15xD holder lengths, see adjustment example above.

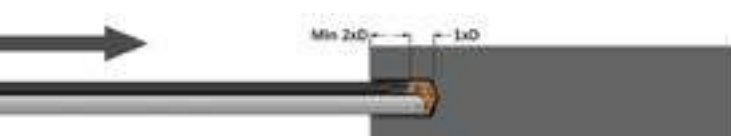
Deep Hole Drilling Guidelines

T-A Pro | 10xD, 12xD, 15xD Holders

<p>1. Pilot Hole 100% RPM 100% mm/rev (IPR)</p>	<p>Establish the pilot hole using the same diameter short drill to a depth of 2xD minimum. Utilise a pilot drill with the same or larger included point angle.</p>  <p style="text-align: right;">Coolant ON</p>
<p>2. Feed-in 50 RPM max 300 mm/min (12 IPM)</p>	<p>Feed the longer drill within 1.5mm (1/16") short of the established pilot hole bottom at a maximum of 50 RPM and 300 mm/min (12 IPM) feed rate.</p>  <p style="text-align: right;">Coolant OFF</p>
<p>3. Deep Hole Transition Drilling 50% RPM 75% mm/rev (IPR)</p>	<p>Drill additional 1xD past the bottom of the pilot hole at 50% reduction of recommended speed and 25% reduction of recommended feed. Minimum of one second dwell is required to meet full speed before feeding.</p>  <p style="text-align: right;">Coolant ON</p>
<p>4. Deep Hole Drilling - Blind 100% RPM 100% mm/rev (IPR)</p>	<p>Drill to full depth at recommended speed and feed for longer drill according to Allied speed and feed charts. No peck cycle recommended.</p>  <p style="text-align: right;">Coolant ON</p>
<p>5. Deep Hole Drilling - at Breakout 50% RPM 75% mm/rev (IPR)</p>	<p>For through holes only: Reduce speed by 50% and feed by 25% prior to breakout. Do not breakout more than 3mm (1/8") past the full diameter of the drill.</p>  <p style="text-align: right;">Coolant ON</p>
<p>6. Drill Retract 50 RPM max</p>	<p>Reduce speed to a maximum of 50 RPM before retracting from the hole.</p>  <p style="text-align: right;">Coolant OFF</p>

⚠ WARNING Tool failure can cause serious injury. To prevent:

- When using holders without support bushing, use a short T-A Pro holder to establish an initial hole that is a minimum of 2 diameters deep.
- Do not rotate tool holders more than 50 RPM unless it is engaged with the workpiece or fixture.

Visit www.alliedmachine.com/DeepHoleGuidelines for the most up-to-date information and procedures. Factory technical assistance is available for your specific applications through our Application Engineering department. email: engineering.eu@alliedmachine.com

Tap Drill Information and Formulas | Metric (mm)

Tap Size	Tap Drill Size	Decimal Equivalent (inch)	* Theo % Thread	Probable Mean Oversize	Probable Hole Size	** Probable % Thread
12 X 1.25	27/64	0.4219	79%	0.075mm	10.79mm	74%
	10.8mm	0.4252	74%	0.075mm	10.88mm	69%
14 X 2.0	15/32	0.4688	81%	0.075mm	11.98mm	78%
	12.0mm	0.4724	77%	0.075mm	12.08mm	74%
14 X 1.5	12.5mm	0.4921	77%	0.075mm	12.58mm	73%
16 X 2.0	14.0mm	0.5512	77%	0.075mm	14.08mm	74%
	14.5mm	0.5709	77%	0.075mm	14.58mm	73%
16 X 1.5	37/64	0.5781	68%	0.075mm	14.76mm	64%
18 X 2.5	15.5 mm	0.6102	77%	0.075mm	15.58mm	75%
18 X 1.5	16.5 mm	0.6496	77%	0.075mm	16.58mm	73%
	21/32	0.6563	68%	0.075mm	16.75mm	64%
20 X 2.5	11/16	0.6875	78%	0.075mm	17.54mm	76%
	17.5 mm	0.6890	77%	0.075mm	17.58mm	74%
20 X 1.5	18.5mm	0.7283	77%	0.075mm	18.58mm	73%
	47/64	0.7344	69%	0.075mm	18.66mm	65%
22 X 2.5	49/64	0.7656	79%	0.075mm	19.52mm	76%
	19.5 mm	0.7677	77%	0.075mm	19.58mm	75%
22 X 1.5	20.5mm	0.8071	77%	0.075mm	20.58mm	73%
	13/16	0.8125	70%	0.075mm	20.71mm	66%
24 X 3	13/16	0.8125	86%	0.075mm	20.71mm	84%
	21.0 mm	0.8268	76%	0.075mm	21.08mm	75%
24 X 2	22.0mm	0.8661	77%	0.075mm	22.08mm	74%
	7/8	0.8750	68%	0.075mm	22.30mm	65%
27 X 3	24.0mm	0.9449	77%	0.075mm	24.08mm	75%

BSP and ISO 7-1

Tap Size	Tap Drill Size	Decimal Equivalent	* Theo % Thread	Probable Mean Oversize	Probable Hole Size	** Probable % Thread
1/4-19	7/16"	0.4375"	-	0.075mm	11.19 mm	-
3/8-19	37/64"	0.5781"	-	0.075mm	14.76 mm	-
1/2-14	23/32"	0.7188"	-	0.075mm	18.33 mm	-
3/4-14	15/16"	0.9375"	-	0.075mm	23.89 mm	-

* Based on nominal tap drill diameter
** Based on 0.075mm probable mean oversize

To calculate the percent of full thread for a given hole diameter:

$$\% \text{ Thread} = \frac{76.93}{\text{Pitch (mm)}} \cdot (\text{Basic major diameter} - \text{Drill hole size})$$

Notes

- The above tap drill information represents probable thread percentages for the standard tap drills stocked at Allied Machine. Special insert diameters may be required in order to meet a user specific percentage of thread requirement.
- The .075mm probable mean oversize hole condition is based on optimum cutting conditions. Probable percent of full thread may vary based on less ideal cutting conditions.
- The table and equations on this page are found in the *Machinery's Handbook*. Permission to simplify and print the equations is granted by the Editor of the *Machinery's Handbook*.

Formulas

- RPM** = $(318.47 \cdot M/\text{min}) / \text{DIA}$

where:
RPM = revolutions per minute (rev/min)
M/min = speed (M/min)
DIA = diameter of drill (mm)
- mm/min** = $\text{RPM} \cdot \text{mm/rev}$

where:
mm/min = mm per minute (mm/min)
RPM = revolutions per minute (rev/min)
mm/rev = feed rate (mm/rev)
- M/min** = $\text{RPM} \cdot 0.003 \cdot \text{DIA}$

where:
M/min = speed (M/min)
RPM = revolutions per minute (rev/min)
DIA = diameter of drill (mm)
- Thrust** = $154 \cdot (\text{mm/rev}) \cdot \text{DIA} \cdot K_m$

where:
Thrust = axial thrust (N)
mm/rev = feed rate (mm/rev)
DIA = diameter of drill (mm)
 K_m = specific cutting energy (kPa)
- Tool Power** = $((\text{mm/rev}) \cdot \text{RPM} \cdot K_m \cdot \text{DIA}^2) / 218604.8$

where:
Tool Power = tool power (HP)
mm/rev = feed rate (mm/rev)
RPM = revolutions per minute (rev/min)
 K_m = specific cutting energy (kPa)
DIA = diameter of drill (mm)

Material Constants

Type of Material	Hardness	K_m (kPa)
Plain Carbon and Alloy Steel	85 - 200 BHN	5.45
	200 - 275 BHN	6.48
	275 - 375 BHN	6.89
	375 - 425 BHN	7.93
High Temperature Alloys	-	9.93
Titanium Alloy	-	4.96
Stainless Steels	135 - 275 BHN	6.48
	30 - 45 RC	7.45
Cast Iron	100 - 200 BHN	3.45
	200 - 300 BHN	7.45
Copper Alloy	20 - 80 RB	2.96
	80 - 100 RB	4.96
Aluminum Alloy	-	1.52
Magnesium Alloy	-	1.10

Troubleshooting Guide

Setup Condition	Potential Problem																				Possible Solutions
	Accelerated corner wear	Barber pole	Bell mouth hole	Insert chipping	Blue chips	Build Up Edge (BUE)	Chatter	Chip packing	Chipping of point	Damaged or broken tools	Excessive margin wear	High flank wear	Hole lead off	Hole out of position	Hole out of round	Oversize hole	Poor hole finish	Poor tool life	Power spikes - Load meter	Retract spiral	
Worn or misaligned spindle (lathe, screw machine, chucker)	1		3				7		9	10	11		13				16	17		20	<ul style="list-style-type: none"> Align spindle and turret or tailstock. Repair spindle.
Use of low rigidity machine tools		2	3	4			7		9	10			13	14						20	<ul style="list-style-type: none"> Reduce penetration rate to fall within the physical limits of the machine or setup (NOTICE: Do not reduce feed below threshold of good chip formation).
Poor work piece support		2		4			7			10	11				15			17		20	<ul style="list-style-type: none"> Provide additional support for the work piece. Reduce penetration rate to fall within the physical limits of the machine or setup (NOTICE: Do not reduce feed below threshold of good chip formation).
Flood coolant, low coolant pressure, or low coolant volume	1				5	6		8		10		12					16	17	18	19	<ul style="list-style-type: none"> Run coolant through tool holder when drilling greater than 1xD. Increase coolant pressure and volume through the tool holder. Reduce penetration rate to fall within the coolant limitations (NOTICE: Do not reduce feed below threshold of good chip formation). Add a peck cycle to help clear chips.
Interrupted cuts. Entry or exit surfaces that are not perpendicular to the spindle (draft angles, parting lines, curved or stepped surfaces, cross holes, and cast or forged surfaces)				4			7		9	10	11		13	14	15	16	17	18			<ul style="list-style-type: none"> Pre-mill (spot face) entry or exit surface to remove interruption. Decrease feed as much as 50% through entry or exit interruption. Use short holders in low impact entry cuts.
Material harder than expected or running tools beyond recommended speed	1				5	6				10		12								18	<ul style="list-style-type: none"> Reduce speed. Increase coolant pressure and volume. Improve coolant condition by use of quality products and regular maintenance.
Poor material micro-structure or foreign particles (forgings and castings that have not been normalised or annealed, poorly prepared steel, flame cut parts, and sand casting)				4		6				10		12	13							18	<ul style="list-style-type: none"> Compare performance of other tools for similar wear problems, which may indicate poor micro-structure. Anneal or normalise parts to improve micro-structure for machining. Reduce feeds (NOTICE: Do not reduce feed below threshold of good chip formation).
Poor chip control								8		10	11		13			16	17	18	19		<ul style="list-style-type: none"> Increase feed to recommended levels. Contact Allied Application Engineering group for technical recommendations. Increase coolant pressure and volume. Improve coolant condition by use of quality products and regular maintenance.
Spot drilled holes with included angle less than that matching T-A Pro or cored holes	1		4				7						13							18	<ul style="list-style-type: none"> Spot hole with short tool of same or greater included angle as T-A Pro drill insert. Reduce feed (NOTICE: Do not reduce feed below threshold of good chip formation). If possible, drill from solid.

Guaranteed Application Form

Distributor PO # _____

The Followig must be filled out completely before your test will be considered

CONTACT DETAILS

Trial P.O No* Date* Proposed Test Date*
 Distributor* Distributor Contact*
 Customer Name* Industry Contact Name*

APPLICATION INFORMATION

ATTENTION: The following information is required to enable the best combination of tooling to be recommended. Please complete all that apply.

Material Type* Specification* Material Hardness Kg BRN RC N/mm²
 Material Condition Flat Stock Round Stock Tubular Stock Plate
 Stacked Plate Hot Rolled Cold Rolled Casting Forging
 Hole Diameter mm Inch Hole Depth Thru Hole Blind Hole
 Drilled Hole Tolerance Req'd Drilled Hole RMS Finished Req'd μInch μMetre

APPLICATION INFORMATION

Material Condition Machining Centre Round Stock Boring Mill
 Multi-spindle auto Multi spindle drill Transfer Line
 Gantry machine Dial Index Machine Radial Arm
 Gun Drilling Machine Pedestal Drill Other

Machine Tool Builder* Model

Machine Tool Control* CNC NC Manual Other

Spindle Orientation* Vertical Horizontal Other

Tool* Stationary Revolves

Available Power* KW HP Available Feed Trust Newtons Lbs
 Available Speed* Variable Fixed RPM m/Min

Preferred Shank Type* Flanged Morse No RCA Lathe Diameter mm Inch

Coolant Type* Cutting Oil Water Soluble Oil Air Mist Air Dry
 Coolant Pressure* Bar PSI
 Coolant Flow Rate* L/min GPM Coolant Supply Through Tool External

CURRENT DRILL INFORMATION

Drill Manufacturer Part Nuber

Drill Type Twist Brazed Indexable Insert Gun Drill
 Removable Tip Other

Tool Grade HSS Carbide Ceramic Other

Tool Coating Uncoated TiN TiCN TiAlN Other

Current Speed RPM m/Min Current Feed Rate mm/rev mm/min

Average Number of Holes Drilled New After Regrind?

Reason(s) for Tool change Wear Fracture Chipping
 Losing Hole Tolerance Losing Chip Control Burr
 Other Chatter New Application

What Criteria defines a successful test* Decreased Cycle Time Better Chip Control Safer Process
 Longer Tool Life Reduced Cost per Hole Other

Potential this application: Current Annual Usage €/£: Tools per Annum?

FOR OFFICE USE ONLY

Application Engineer: Number: Status:

Europe

Allied Machine & Engineering Co. (Europe) Ltd.

93 Vantage Point
Pensnett Estate
Kingswinford
West Midlands
DY6 7FR England

Phone:

+44 (0)1384 400900

Email:

enquiries.eu@alliedmachine.com

Web:

www.alliedmachine.com

Wohlhaupter GmbH

Maybachstraße 4
72636 Frickenhausen
Germany

Phone:

+49 (0)7022 408 0

Email:

info@wohlhaupter.de

Web:

www.wohlhaupter.com

United States

Allied Machine & Engineering

120 Deeds Drive
Dover OH 44622
United States

Phone:

+1 330 343 4283

Fax:

+1 330 602 3400

Toll Free USA and Canada:

800 321 5537

Toll Free USA and Canada:

800 223 5140

Allied Machine & Engineering

485 W Third Street
Dover OH 44622
United States

Phone:

+1 330 343 4283

Fax:

+1 330 364 7666
(Engineering Dept.)

Toll Free USA and Canada:

800 321 5537

Asia

Wohlhaupter India Pvt. Ltd.

B-23, 3rd Floor
B Block Community Centre
Janakpuri, New Delhi - 110058
India

Phone:

+91 11 41827044

Your local Allied Machine representative:



**ALLIED MACHINE
& ENGINEERING**

WOHLHAUPTER®

Holemaking Solutions for Today's Manufacturing